

NATIONAL INSTITUTE FOR EMPOWERMENT OF PERSONS WITH
MULTIPLE DISBILITEIS (NIEPMD)

(Department of Empowerment of Persons with Disability (Divyangjan), Ministry of Social Justice & Empowerment, Govt. of
India)

E.C.R. Muttukadu, Kovalam P.O, Chennai- 603 112

**TENDER DOCUMENT: RATE CONTRACT FOR SUPPLY AND INSTALLATION OF
FURNITURE ITEMS AT NIEPMD AND ITS EXTENTIONS CENTERS**

FILE NO. NIEPMD/PUR 4 (10)/2017-18

E- Tender is invited through NIC e-procurement portal URL <http://eprocure.gov.in/eprocure/app> in two bid system i.e. **(I) Technical Bid (II) Financial Bid** from competent & reputed manufacturers/ authorized distributors/ dealers for supply and installation of furniture items at NIEPMD, Muttukadu and its extensions centres. The tenderer should having proven track record in supplying of furniture items to Central Govt. / State Govt. / Autonomous bodies/ PSUs/ institutes / colleges. The bidder must have a minimum experience of 05 years for supplying furniture items as on 01st Apr 2017, the same should be supported by proper testimonials certificates. The bidder must have an annual average turnover of last 03 financial years should not be less than Rs. 2 crores (i.e. minimum 6 crore in 3 FYs.). Tenderers should read the tender document carefully as enclosed and comply strictly with the conditions, while uploading their bids. Clarifications, if any, may be sought from the NIEPMD purchase Division on Telephone No 044-27472113 Extn. 413. Tender format can be downloaded from our website www.niepmd.tn.nic.in . Clarification also can be mailed to mail id niepmd@gmail.com. asponiepmd@gmail.com. The tender document can also be downloaded from over website www.niepmd.tn.nic.in.

Last date for E-bidding	- 02.00 PM. on	27-04-2017
Tender fee	- Rs.1, 000/-	
EMD Amount	- Rs. 1,00,000/-	
Date & Time of Opening of Technical Bids	- 03.00 PM. on	28-04-2017

Tele: 044-27472046/27472113 Telefax: 044-27472389 Email:niepmd@gmail.com

DIRECTOR

NATIONAL INSTITUTE FOR EMPOWERMENT OF PERSONS WITH
MULTIPLE DISABILITIES (NIEPMD)

(Department of Empowerment of Persons with Disability (Divyangjan), Ministry of Social Justice & Empowerment, Govt. of India)

E.C.R. Muttukadu, Kovalam P.O, Chennai- 603 112

**TENDER DOCUMENT: RATE CONTRACT FOR SUPPLY AND INSTALLATION OF
FURNITURE ITEMS AT NIEPMD AND ITS EXTENSIONS CENTERS**

FILE NO. NIEPMD/PUR 4 (10)/2017-18

E- Tender is invited through NIC e-procurement portal URL <http://eprocure.gov.in/eprocure/app> in two bid system i.e. **(I) Technical Bid (II) Financial Bid** from competent & reputed manufacturers/ authorized distributors/ dealers for supply and installation of furniture items at NIEPMD, Muttukadu and its extensions centres. The tenderer should have proven track record in supplying of furniture items to Central Govt. / State Govt. / Autonomous bodies/ PSUs/ institutes / colleges. The bidder must have a minimum experience of 05 years for supplying furniture items as on 01st Apr 2017, the same should be supported by proper testimonials certificates. The bidder must have an annual average turnover of last 03 financial years should not be less than Rs. 2 crores (i.e. minimum 6 crore in 3 FYs.). Tenderers should read the tender document carefully as enclosed and comply strictly with the conditions, while uploading their bids. Clarifications, if any, may be sought from the NIEPMD purchase Division on Telephone No 044-27472113 Extn. 413. Tender format can be downloaded from our website www.niepmd.tn.nic.in. Clarification also can be mailed to mail id niepmd@gmail.com. asponiepmd@gmail.com. The tender document can also be downloaded from our website www.niepmd.tn.nic.in.

Last date for E-bidding	- 02.00 PM. on	27-04-2017
Tender fee	- Rs.1, 000/-	
EMD Amount	- Rs. 1,00,000/-	
Date & Time of Opening of Technical Bids	- 03.00 PM. on	28-04-2017
06-04-2017		

Tele: 044-27472046/27472113 Telefax: 044-27472389 Email:niepmd@gmail.com

DIRECTOR

National Institute for Empowerment of Persons with Multiple Disabilities (NIEPMD) is a Central Autonomous Body under the Ministry of Social Justice & Empowerment, Government of India. The Institute intends finalize Annual Rate Contract for supply and installation of furniture as listed to appendix "A" to tender document to institute for a period of One year after finalisation of contract. Contract may be extended for two more year subject to satisfactory performance and discretion of Director, NIEPMD. However tenderer has got full right not to extend the rate contract beyond one year.

NIEPMD is inviting e- tenders from reputed furniture manufactures and their authorised suppliers & Distributers having proven track record in supplying furniture materials for minimum 05 years and with an average annual turnover of not less than Rupees **2 Crores** (i.e. minimum 6 crore in 3 FYs.) for last 03 financial Years. The materials to be supplied as per the specifications mentioned in the scope of work provided in Tender Notice as per appendix "A". Interested bidders can apply on line through NIC e-procurement portal URL <http://eprocure.gov.in/eprocure/app>. Copy of Notice Inviting Tender can also be downloaded from the institute's website www.niepmd.tn.nic.in.

Date: 15th Mar 2017

Director

SUPPLY AND INSTALLATION OF FURNITURE ITEMS AT NIEPMD, CHENNAI AND ITS EXTENSION CENTRES

1. Parties:

The parties to the Contract are the Tendering Firm and National Institute for Empowerment of Persons with Multiple Disabilities (NIEPMD).

2. Scope of Work

Supply and installation of furniture items in NIEPMD Chennai under annual rate contract as described in Appendix "A" to tender document.

3. Eligibility Conditions:

(a) The manufacturers/ authorized distributors / dealers, who have an average annual turnover of Rs. 2,00,000,00/- (Rupees Two Crores) during last three financials years (2013-14, 2014-15 and 2015-16) shall only be eligible.

(b) The Manufacturer must have good quality management system conforming to International Standards like ISO 9001-2008.

(c) The Technical bid must be accompanied by the manufacturer's catalogue / brochures and photograph etc. (in Original) in respect of the product offered.

(d) The Firm should have a solvency of **Rs. 1 Crore** certified by its Bankers. (Certificate issued by bank to be attached).

(e) The supplier should be either itself a manufacturer or authorized distributor/ dealer of the manufacturer. Proof to be uploaded with technical bid.

(f) The tenderer should have successfully executed at least three supply orders of similar nature and value of Rs. 50 lac each (03 orders) or 02 supply order of Rs. 75 lakh or above each or single supply order of value Rs. 1 crore to Central/ State Government/ PSU Departments/ organizations/ reputed educational institutions in the last three years. Copies of these supply orders should be uploaded with the Technical Bid.

(g) The Tenderer should have PAN No., TIN No. and VAT No. and should upload legible attested copies of PAN No., TIN No. and VAT No. with Technical Bid. Technical Bid not accompanied by these documents would be summarily rejected.

4. Preparation and Submission of Tender:

Interested bidder may submit their quotes by giving all the necessary documents in English or Hindi as specified. **The TENDER must be submitted online through Central Public Procurement Portal e-procurement application only through URL: <http://eprocure.gov.in/eprocure/app> only. No manual bids will be entertained under any circumstances.**

The Tender document attached must be direct, concise, and complete and arranged in an organized and structured manner.

To participate in online bidding process, Bidders must procure a Digital Signature Certificate as per Information Technology Act-2000 using which they can digitally sign and encrypt their electronic bids. Bidders can procure the same from any CCA approved certifying agency, i.e. TCS, Safecrypt, Ncode, eMudhra etc. Bidders who already have a valid Digital Signature Certificate (DSC) need not procure a new DSC.

NIEPMD will not be responsible for delay in online submission due to any reason. For this, bidders are requested to upload the complete bid proposal well advance in time so as to avoid issues like slow speed, choking of web site due to heavy load or any other unforeseen problems.

Bidders are also advised to refer visit any local NIC office or call CPPP 24x7 toll free number 1800-3070-223 or mobile No. 07878007972, 07878007973 for further details about the e-tendering / bidding process.

5. Procedure for e-payment:

EMD of Rs. 1,00,000/- and Tender fee of Rs. 1,000/- (Non-refundable) should be paid online through NEFT or RTGS in NIEPMD account and payment receipt to be uploaded with technical bid. Technical bids without EMD and Tender Fee shall not be considered for further evaluation. NIEPMD Bank details are as follows:

A/C No. 761297290

Type of Account: Saving Bank

Name of Bank: Indian Bank, Kovalam Branch

IFS Code: IDIB000K122

Branch Code: 01176

- **Caution:** Please ensure that you need to mention the correct beneficiary account number and IFSC code as mentioned above while making payment via RTGS / NEFT. In the event of funds remitted to wrong beneficiary account number, NIEPMD, Chennai or its Bank would not responsible for the same.
- **It also requested that bidder should upload his complete bank detail on letter Head for returning of EMD amount through bank transfer in case not qualifying as L-1 bidder.**

IMPORTANT INSTRUCTIONS AND GENERAL TERMS AND CONDITIONS

2. Read the tender documents carefully before uploading.
3. Sign each page of NIT with seal and upload with technical bid.
4. Detailed tender can be downloaded from the Institute website www.niepmd.tn.in. Please refer Tender section on the Home Page of the Website. Amendment to the tender will be made only on the website and NIC e-procurement portal and no notification thereof should be given in newspapers. **Please keep visiting our website for any corrigendum / amendments and submit the bid documents accordingly. Changes made in the tender documents due to reasons beyond the control of the Institute will be uploaded on the website only and no additional notification will be issued in Newspaper.**

The technical bid should be accompanied tender fee payment receipt for Rs.1000/- and EMD payment receipt of Rs. 1,00,000/- paid in NIEPMD account towards the cost of the processing fees. Application without the prescribed fee and EMD will not be considered and summarily rejected.
5. The tender should be submitted in two parts viz. Technical Bid and Financial Bid
6. Earnest Money Deposit and tender fees as mentioned in the Tender document shall be paid separately.
7. The technical bid will be opened at 03.00 P.M. on 28th Apr 2017 in the presence of the authorised representatives of the tenderers.
8. Any tender uploaded with any correction, amendments, overwriting etc. shall be considered invalid and shall be rejected, except if duly initialled with seal of the tenderer.
9. The tender is liable to be ignored if complete information is not given there-in, or if the particulars and data (if any) asked for in the schedule to the tender are not filled in.
10. The financial bids of only those Tenderers whose technical Tenders are recommended by competent committee / authority will be opened at a later date or same day. The date & time of opening the financial bid will be intimated to the

Tenderers in advance through E-mail only or will be intimated during opening of technical bid.

11. During the opening of the two-bid Tender the name of Tenderers who have submitted their offers along with details of Earnest Money Deposit will only be read out and no other information/details whatsoever, will be shared at this stage.
12. In deciding upon the selection of Vendors for the work, great emphasis will be put on the ability and competency of Vendors to provide high quality services in a time-constrained environment at cost-effective rates.
13. NIEPMD, Chennai reserves the right to accept/reject any Tender in part or full, without assigning any reason whatsoever.
14. If the last date of opening of the Tenders coincides with a holiday, then the next working day shall be the opening date. However Director NIEPMD, Chennai reserve the right to extend last of tender, opening of tender without assigning of any reason. Decision of Director, NIEPMD will be final and binding.
15. Evaluation will be done against item wise rate for those items which are technically accepted by tender committee. **Catalogue for each item therefore must be submitted in technical bid with SL. No of Items.**
16. TDS and any other Government levies applicable on bills as per Government instructions/ notifications issued from time to time shall be applicable and deducted from Service Provider's bills.
17. The insurance of the equipment and staff utilized in this service will be borne by the service provider. A copy of staff insurance document shall be produced to the Institute.
18. In case of any dispute the jurisdiction of the matter will be within the limits of Chennai City only.
19. Periodic service of furniture is to be undertaken by the service provider to ensure uninterrupted quality till one year or warranty period whichever is higher.
20. In the event of any question, dispute or difference arising under this NIT or in connection there with except as to matter the decision of which is specifically provided under this NIT, the same shall be referred to an arbitrator to be appointed by the Director, NIEPMD, Chennai and the decision of the arbitrator will be binding on both parties of this NIT.
21. The Tender should be complete in all respects and should be duly signed. Incomplete tender will be directly rejected. **Tenderer must ensure for quote rate for each items which are given in financial bid / BOQ.**
22. **Displaying of Furniture Item Sample: The L-1 bidders will be asked to display the sample of furniture item in front of technical committee within**

10 days after opening of Price bid. In case rejection of sample lowest bidder, L-2 bidder will be asked to display the sample. No L-1 bidder will be exempted from displaying the sample none displaying of sample by L-1 bidder will lead to rejection of bid. Cost involve in showing item sample will be borne by bidder himself. No financial impact will be borne by Institute.

23. **Registered office:** The bidders must have its registered office in Chennai / Tamilnadu for in time after sale support. Proof in this regard must be uploaded with technical bid
24. **AMC:** Successful bidder / bidders will be required to provide AMC including spares parts till warranty period or 1 year from date of award of order. This will be done on zero cost basis
25. **EXPERIENCE :** The tenderer should have satisfactory service record with other reputed Organizations, which should include at least three reputed Public Sector Undertaking/CG State Govt./Department of the Govt. of India.(A valid performance certificate (Three) and Three PO as of proof of above should an essential enclosure in the proposal).
26. **ANNUAL TURNOVER:** Annual Turnover should be Rs.2,00,000/- (2 crores) or more during last 3 financial years i.e. 2013-2014, 2014-2015, 2015-2016. Complete audited annual turnover report with profit & Loss statement, balance sheet, income and expenditure reports for last 3 years to be uploaded along with the technical bid.
27. **STATUTORY REGISTRATIONS:** The tenderer must have valid PAN No. and TIN/VAT No. Photocopy of PAN Card of the Firm / OEM /Dealer / Proprietor and VAT / Trade Tax return for last 3 years is to be uploaded with the technical bid.
28. **SHOP:** Copy of Registration of Shop and Establishment must be uploaded with the technical bid.

IMPORTANT INFORMATION FOR THE BIDDERS

1. Information required with Tender: The following documents/information are required to be uploaded along with offer:

- Copy of Registration of firm
- Copy of Service tax registration
- Copy of VAT/TIN/CESS registration
- Power of attorney attached in favour of person signed the documents
- Copy of Income Tax PAN registration
- Copy of Registration of Shop and Establishment in Chennai / Tamilnadu.
- Copy of 5 years' experience certificate as described above with required proof.
- Copy of EMD & Tender Fees deposit.

Detail list of enclosures is updated in Check list listed as "Appendix C" to tender document.

2. **Expenses to be borne by bidder:** All expenses in preparation and submission of bids and visits to the office or any place in connection with the preparation of the Bid and displaying materials sample shall be borne by the Bidder. NIEPMD in no case shall be responsible or liable for these costs regardless of the outcome of the bidding process.
3. **Prices, Taxes, Duties:** The bidder should quote firm prices/ rates taking into account of all taxes, duties, levies, personal tax, corporate tax and all other expenditure required to be incurred by him/ her for providing required services etc. during the contract period as indicated under this contract and after wards no variation on any account unless otherwise specifically mentioned will be allowed.
4. **Bid Validity:** Bid submitted by bidder shall remain valid for a period of 120 days from the date of opening of offer. Bidder shall not be entitled during this period to revoke or vary the content of Bid or any term thereof. In such case of making any variation subsequent to submission of bid at their own, the offer shall be treated as "REJECTED" and EMD shall be forfeited without any reference to the bidder.
5. **Place and Address for submission of Bids :** Bids should be submitted through NIC e-procurement portal URL <http://eprocure.gov.in/eprocure/app> only.
6. **Contract Agreement:** The successful Bidder shall be required to execute a contract Agreement with NIEPMD on the non-judicial stamp paper of Rs. 100/- (Rupees One hundred only). The cost of stamp paper shall be borne by successful bidder.

NIEPMD reserves the right to amend the terms & conditions of contract by mutual discussions and shall be in writing during the tenure of the contract. The amended terms and condition will form part of the agreement.
7. **Jurisdiction:** It is agreed and declared by and between the parties hereto that so far it concerns the jurisdiction of any court in enforcing any of the rights or remedies of the parties hereto against each other or one another, a court in the city of Chennai alone shall have jurisdiction to the exclusion of all other courts in any place in the Union of India so that none of the parties hereto shall be entitled to any proceedings whatsoever in respect of any matters touching or relating to or in connection with or arising under agreement and the terms and conditions thereof in any court except the court or courts having jurisdiction in the city of Chennai.
8. **Authorization:** The Vendor shall submit to the institute the names, designation and specimen signatures of the persons authorized by him to deliver and install materials, sign joint measurements, bills, receive payments, receive instructions / notices etc. on behalf of the Vendor.

9. **Access to site:** The Vendor shall allow unhindered access to the institute and/ or any other party or person, engaged by the Institute to work at the same site and /or to check / regulate /watch /guard/ measure/ inspect, solely or jointly with the Vendor.

10. **Safety and Security:** Vendor shall abide by the safety code provisions as per safety code framed from time to time by the government.

11. **RIGHT RESERVED BY THE INSTITUTE:** The Institute i.e NIEPMD, Chennai reserves the right to accept or reject any or all the tenders without assigning any reason and shall also be subject to the availability of budget.

12. **PAYMENT:** Payment shall be made within 30 working days after satisfactory receipt of complete stores mentioned in the purchase orders. No advance payment will made under any circumstances.

13. **Quantity of item:** The tenderers may note that quantities mentioned in the price bid are only tentative in nature and are meant only for the purpose of evaluation of tender. Actual procurement quantities of items may differ which may increases or decreases and may also not be required any or complete line items which is/are mentioned in BOQ.

14. Right of Acceptance and Other Provisions:

(a) The acceptance of the tender rests with NIEPMD. The Institute is not bound to accept the lowest tender bid and reserves the right to accept or reject any or all the bids without assigning any reasons thereof. NIEPMD also reserves the right to modify and/ or relax, any terms & conditions of this tender document to safeguard its interest. The Director, NIEPMD can extend last date of tendering and can change the date of bid opening without assigning any reason.

(b) The Institute reserves the right to cancel bid if it is found that the items produced for inspection/ supplied do not meet the specifications.

(c) NIEPMD reserves the right to black list a defaulting vendor.

(d) Any inquiry after submission of the tender will not be entertained.

(e) Any failure on the part of the bidder to observe the prescribed procedure and any attempt to canvas for the purchase order will prejudice the firm's quotation.

(f) NIEPMD reserves the right to cancel the tender process without assigning any reason whatsoever, at any stage.

15. Warranty (12 Months Onsite Warranty including Spare Parts):

- (a) The vendor **will provide minimum 12 months comprehensive Onsite Warranty including spare parts etc.**, from the date of completion of supply and installation of the items.
- (b) In case of any claim arising out of this warranty, the NIEPMD shall promptly notify the same in writing to the vendor.
- (c) Upon receipt of such notice, the vendor shall, within 48 hours on a 24(hrs) X 7 (days) X 365 (days) basis respond to take action to repair or replace the defective equipment or parts thereof, free of cost, at the ultimate destination. The vendor shall take over the replaced parts/ equipment after providing their replacements and no claim, whatsoever shall lie on the purchaser for such replaced parts/ equipment thereafter. The penalty clause for non-replacement will be applicable as per the penalty clause.
- (d) In the event of replacement of defective equipment during the warranty period, the warranty for the replaced equipment shall be extended for a further period.
- (e) If the vendor, having been notified, fails to respond to take action to replace the defect(s) within 48 hours on a 24(hrs.) X 7 (days) X 365 (days) basis, the purchaser may proceed to take such remedial action(s) as deemed fit by the purchaser, at the risk and expense of the vendor and without prejudice to other contractual rights and remedies, which the purchaser may have against the vendor, including forfeiture of the performance security/ bank guarantee.

16. Delay in the Vendor's Performance:

- (a) The vendor shall deliver the furniture items to NIEPMD, Chennai under the contract within the time schedule specified by the NIEPMD in the Schedule of Requirements and as incorporated in the contract. The time and the date schedule of delivery of the equipment mentioned in the Schedule of Requirements (SOR)/ Incorporated in Contract shall be deemed to be of the essence of the contract and the delivery must be completed no later than the date (s) as specified in the contract / supply order.
- (b) Subject to the provisions of the tender, any delay by the vendor in maintaining its contractual obligations towards delivery of the equipment and performance of services shall render the vendor liable to any or all of the following sanctions:
- i) Imposition of liquidated damages,

- ii) Forfeiture of its performance security and
- iii) Termination of the contract for default.
- iv) Blacklisting the vendor.

17. Penalty: In the event of the firm failing to:

- a. Observe or perform any of the conditions of the work order as set out herein; or
- b. Execute the order in good condition to the satisfaction of NIEPMD or by the time fixed by NIEPMD.

(a) It shall be lawful for NIEPMD, in its discretion, in the former event to remove or withhold any part of the order, until such times as it may be satisfied that firm is able to do and will duly observe the said conditions and in the latter event to reject or remove as the case may require any order executed otherwise than in a good condition and to the satisfaction of NIEPMD and by the time fixed by it and in both or either of the events aforesaid to make such arrangements as it may think fit for the execution of the order so removed or order in lieu of that so rejected or removed as aforesaid on account and at the risk of the firm.

(b) Provided further that if in either event any excess cost be incurred by reason of the difference between the prices paid and the accepted rates, NIEPMD may charge the amount of such excess cost to the firm and the same may at any time thereafter be deducted from any amount that may become due to the firm under this or any other contract, or maybe demanded of him to be paid within fourteen days to the credit of the NIEPMD.

(c) In the event of discovery of any error or defect due to the fault of the Firm/ vendor at any time after the delivery of goods ordered, the Firm/ vendor shall be bound, if called upon to do so, to rectify such error or defect at his own cost to the satisfaction of and within the time fixed by NIEPMD. In the event of the delivery of any defective work, which owing to urgency or for any other reason cannot be wholly rejected NIEPMD shall have the power to deduct from any payment due to the firm such sum as it may deem expedient.

(d) If the vendor fails to deliver any or all of the equipment or fails to perform the services within the time frame(s) incorporated in the contract, the NIEPMD shall, **without prejudice to other rights and remedies available to the NIEPMD under the contract, deduct from the contract price, as liquidated damages, a sum equivalent to 5% per week of delay or part thereof on delayed supply of equipment/ replacement parts and/ or services until actual delivery or performance, subject to a maximum of 15% of the contract price.** Once the maximum liquidated damages/ or a period of 28 days, whichever is earlier, are reached, the NIEPMD may consider termination of the contract.

- (e) In the event of work being wholly rejected, NIEPMD may at its discretion may either:
- (i) Permit the Firm/vendor to re-do the same within such time as it may specify at Firm's own cost of all sorts i.e. materials, labour, Equipments, overheads, transportation etc.;
 - or
 - (ii) Arrange to get the additional work done elsewhere and by any other person or from any other source than the Firm/vendor in which case the amount of extra cost, if any, shall be recovered from the Vendor in the manner provided in sub clause(b) of this clause.

18. Statutory Obligations:

- (a) All statutory obligations under various laws from time to time shall be borne by vendor for which no extra payment shall be made at any time during the contractual period.
- (b) The vendor shall at all times indemnify and keep indemnified the owner and its officers, employees, agents and students from and against all third party claims whatsoever (including time and shall not be limited to property loss and damages, personal accidents, injury or death of persons or servants or agents of any vendor/sub- vendor(s) and the vendor shall at his own cost and initiative at all time, maintain all liabilities under Workman's Compensation Act, Fatal Accident Act, Personal Injuries, Insurance Act and/or any other relevant Industrial Legislation, which is in force from time to time).

19. Breach of Terms and Conditions: NIEPMD may terminate the contract without any notice in case the vendor commits a breach of any of the terms of the contract. NIEPMD's decision that a breach has occurred will be final and shall be accepted without demur by the vendor.

20. Subletting of Work: The vendor shall not assign or sublet the work or any part of it to any other person or party.

23 Right to Call upon Information Regarding Status of work:

NIEPMD has the right to call upon information regarding status of work at any point of time.

21. Terms of Payment:

(a) Items are to be supplied by the tenderer at NIEPMD Chennai and its extension centres. Materials will be delivered free of cost to NIEPMD, Muttukadu, however for supplying materials to extension centres transportation charges in the cheapest mode will be paid by NIEPMD on production of original transportation receipts with invoices.

(b) Payment for Materials supplied to extensions centres will be made on producing duly signed clear receipt of delivery challan from extension centres.

(c) Payment shall be made through NEFT transfer or account payee cheques only and TDS as applicable will be deducted, after satisfactory supply, installation and commissioning of the said items. No cash payment will be made.

(d) NIEPMD shall be at liberty to withhold any of the payments in full or in part subject to recovery of taxes including TDS as applicable and recovery of penalties mentioned in preceding para.

20. Earnest Money Deposit (EMD):

(a) The Technical Bid must be accompanied by Earnest Money Deposit of Rs 1,00,000/- submitted online through NEFT to NIEPMD account.

(b) The EMD of unsuccessful bidders will be discharged/ returned to them after placing of the order to the successful vendor.

(c) Earnest Money is required to protect the purchaser against the risk of the bidder's conduct, which would warrant the forfeiture of the EMD. Earnest money of a bidder will be forfeited, if the bidder withdraws or amends its tender or impairs or derogates from the tender in any respect within the period of validity of its tender or if it comes to notice that the information/documents furnished in its tender is incorrect, false, misleading or forged without prejudice to other rights of the purchaser.

(d) The successful bidder's EMD will be forfeited without prejudice to other rights of the purchaser, if it fails to furnish the required performance security within the specified period.

(e) No interest will accrue on the EMD/ performance security deposit.

21. Performance Security:

The vendor selected would be required to furnish a Performance Security equal to 10% of the cost of the supply order in the form of Demand Draft/ FDR/ Bank Guarantee from any Scheduled Bank in favour of "Director, NIEPMD, Chennai" payable at Chennai. In case the Performance Security is submitted in the form of Bank Guarantee, the same should be valid for a period of the date of expiry of the

contract. NIEPMD reserves the right to ask for performance guarantee extension if contractual obligations are not fulfilled.

22. Force Majeure:

(a) For purpose of this Clause, "Force Majeure" means an event beyond the control of the Vendor and not involving the Vendor's fault or negligence and not foreseeable. Such events may include, but are not limited, acts of the Institute either in its sovereign or contractual capacity, wars or revolutions, fires, floods, epidemics, quarantine restrictions and freight embargo.

(b) If a Force Majeure situation arises, the Vendor shall promptly notify the Institute in writing of such conditions and the cause thereof. Unless otherwise directed by the Institute in writing, the Supplier shall continue to perform its obligations under the Purchase Order as far as is reasonably practical, and shall seek all reasonable alternative means for performance not prevented by the Force Majeure event.

Appendix “ A”

SCHEDULE FOR REQUIREMENT (SOR)

Sl. No.	Material Detail	Qty. Req.
1.	Computer Table	20 Nos.
2.	Executive Table with 10mm table glass	20 Nos.
3.	Clerical table	40 Nos.
4.	2 Seater Desk cum Bench	50 Nos.
5.	6 Seater reading table for Library	10 Nos.
6.	4 Drawer Library Bookcase	20 Nos.
7.	Filing Cabinet 4 Drawer with metal top	30 Nos.
8.	3 Seater SS Visitor Chair	30 Nos.
9.	Executive Revolving Chairs High Back with wheel	20 Nos.
10.	Chairs Medium Size (with wheels)	30 Nos.
11.	Chairs (Steel frame) without wheel	20 Nos.
12.	Computer Chair	20 Nos.
13.	Wire Netted S type Chair Teak Wood Frame With Arms	30 Nos.
14.	Wire Netted S type Chair Teak Wood Frame without Arms	20 Nos.
15.	5 seater Sofa Set (3x1x1 pattern)	05 Nos.
16.	Chair with writing pad	40 Nos.
17.	Steel Almirah (H)1980 x (W)915 x (D)480mm	60 Nos.
18.	Steel Almirah (H)1270 x (W)760 x (D)430mm	10 Nos.
19.	Steel Almirah (H)915 x (W) 610 x (D)380mm	05 Nos.
20.	Glass Door Display Almirah	10 Nos.
21.	4 Drawer Library Steel Book Case	20 Nos.
22.	Wardrobe	10 Nos.
23.	BED / Coats	100 Nos.
24.	Mattress for BED / Coats	100 Nos.
25.	Industrial Locker (12 Compartments)	10 Nos.
26.	Industrial Locker (16 Compartments)	10 Nos.
27.	Industrial Lockers (24 Compartments)	10 Nos.
28.	Door Covered Shoe Rack	20 Nos.
29.	Dining table 10 Seater	04 Nos.
30.	Dining Table 8 seater	04 Nos.
31.	Dining Chairs	60 Nos.
32.	Study table for hostel	20 Nos.
33.	Study Chair	40 Nos.
34.	Periodicals Display Rack	10 Nos.
35.	Step stool	05 Nos.
36.	White Board 2'x3'	10 Nos.
37.	White Board 4'x3'	20 Nos.
38.	White Board 4'x6'	10 Nos.
39.	White Board 4'x8'	05 Nos.
40.	White Board 8' x 3'	05 Nos.
41.	Acrylic Door Covered Felt Notice Board 4'x3'	10 Nos.
42.	Acrylic Door Covered Felt Notice Board 4'x6'	05 Nos.
43.	Acrylic Door Covered Felt Notice Board 4'x8'	05 Nos.

44.	White Magnetic Board 2'x3'	10 Nos.
45.	White Magnetic Board 4'x3'	05 Nos.
46.	White Magnetic Board 4'x6'	05 Nos.
47.	White Magnetic Board 4'x8'	05 Nos.
48.	Felt Board 2' x 3'	05 Nis.
49.	Felt Board 4' x 3'	10 Nos.
50.	Felt Board 4' x 6'	05 Nos.
51.	Felt Board 4' x 8'	05 Nos.
52.	Combination Board 4' x 3'	10 Nos.
53.	Combination Board 4' x 6'	05 Nos.
54.	Combination Board 4' x 8'	05 Nos.
55.	Acrylic door covered Aluminium wall mounting Key Hanging Box for provision of 50 Keys.	10 Nos.
56.	Godrej Halo Very High Back Chair	02 Nos.
57.	Godrej Halo High Back Chair	02 Nos.
58.	Godrej Halo Revolving Visitor	10 Nos.
59.	Godrej Push Pull type optimizer 3 Portion	02 Nos.
60.	Green Class room chalk writing board 4 feet x 8 feet	05 Nos.
61.	Nilkamal Heritage with Arm Chair	20 Nos.
62.	Nilkamal CHR 4002 without arm chair	20 Nos.
63.	Nilkamal STL 10 round stool	10 No.
64.	Nilkamal STL-15 Squire Stool	10 Nos.

Detailed specification of above furniture is attached as Appendix “D” to this document.

Technical Bid

The technical bid shall contain following information:-

1. Name & Postal address of Vendor:

Telephones Nos.:

E-mail:

Fax Nos.

Mobile Nos:

2. Name & address of Owners/ Partners/ Directors :

3. If Registered, Reg. No with validity of registration with appropriate authority (Attach Copy of Certificate):

4. TIN/ Sales/ Service Tax Reg. No. (Attach Copy of Certificate):

5. PAN No. (Attach Copy of Certificate):

6. Details of the turnover for the last three financial years (**indicate year wise and attach audited document**):

- (a) FY 2013-14 -
- (b) FY 2014-15 -
- (c) FY 2015-16 -

7. Attach Work order/ Certificate in support of experience for having undertaken Supply and installation of furniture items in the last Five years (at least one proof for each year).

8. List of 3 reputed clients, with at least one client belonging to GOI/ State Govt. Dept./ PSU/ Autonomous Bodies reputed educational institutions with telephone No.:

- (a) Client 1 -
- (b) Client 2 -
- (c) Client 3 -

9. Has your organization been placed in defaulter category by any Govt. Department/ PSU/ Reputed Educational Institution? If not, please submit a self-attested certificate to this effect.

10. Are you related in any way with any staff member of the NIEPMD: Yes/ No.

11. Details of clients with name, complete address and contact person with telephone number where the Vendor has done supply and installation of furniture items in Chennai / Tamilnadu.

- (a) Client 1 -
- (b) Client 2 -
- (c) Client 3 -

12. The tender document should be **duly signed on each page.**

Signature of the Proprietor/ Authorized Signatory

Rubber Seal indicating complete address

Place :

Date :

Appendix “B”

CHECK LIST

The Technically Bid shall be summarily rejected, if these documents are not uploaded. Documents must be uploaded in following serial order only.

Sl. No.	Particulars	Yes / No
1.	Name, address & telephone number of the agency/firm	Attach Proof
2.	Name, designation, address & telephone number of authorized person	Attach Proof
3.	Please specify as to whether Tenderer is sole Proprietor / Partnership Firm/Private or Limited Company.	Attach Proof
4.	Name, address & telephone number of Directors / Partners, Fax No., e-mail address	Attach Proof
5.	Receipt of Tender Fee payment for `1000/- (Rupees One Thousand only) to be uploaded. (Non-Refundable) . (In case of exemption pl. attach proof)	Attach Proof
6.	Receipt for EMD payment of ` 1,00,000/- (Rupees One Lac Only) to be uploaded. (In case of exemption pl. attach proof)	Attach Proof
7.	Address proof of Registered office in Chennai / Tamilnadu. .	Attach Proof
8.	Firm / Company Registration certificate (Copy to be uploaded)	Attach Proof
9.	Certificate by the bidder to be uploaded stating that the firm / company has not been black listed by any Central Govt. / State Govt. / PSU agencies.	Attach Proof
10.	Certificate by the bidder to be uploaded that they have read and understand all the term and conditions mentioned in the tender document.	Upload undertaking
11.	Copy of appropriate PAN Card	Attach Proof
12.	Copy of Registration with Service Tax/ Sales Tax/ VAT Department.	Attach Proof
13.	Technical specification broacher of quoted models is support of technical data of quoted model. (Must uploaded). In case of non-availability product brochure with technical bid it may cause rejection of bids technically. Product where brochure not available vendor should provide complete technical detail of material on his letter head.	Attach Proof
14.	Valid ISO certification of firm / agency.	Attach Proof
15.	Undertaking to supply on credit of 30 days after clear receipt of materials. (Self-Certificate on company letter head to be uploaded)	Upload undertaking
16.	Undertaking regarding rates will be firm during contract period. (Self-Certificate on company letter head to be uploaded)	Upload undertaking
17.	Copy of Income Tax Return of the firm/company/agency (Individual in case sole proprietary firm) for last 03 financial years.	Attach Proof
18.	Experience Certificates / details of 5 years in supplying of Furniture Equipments to the office of Central Government / State Government/Public Sector Undertakings/Autonomous Bodies/Organizations (Proof of experience of 05 years in the business	Attach Proof

	of supplying and installation of furniture Equipments to be uploaded.)	
19.	Certified copies of abridged balance sheets along with profit & loss account of the firm (tenderer) in support of average annual financial turnover during the last 3 year years, ending 31st March 2016 of the previous financial year, should be at least 2 Crore . (Attach Proof)	Attach Proof
20.	The Bidder must either be the Original Equipment Manufacturer (OEM) or an authorized dealer. In case of OEM, Proof of being Original Equipment Manufacturer (OEM) or authorized dealer must be uploaded OR In case of authorized representative of OEM - current authorization from the OEM must be uploaded. OR In case of Authorised distributor of OEM detailed and valid agreement between Distributor and the OEM(s) defining clearly the role, responsibility, scope of work and contribution towards the tendered Equipment/System for each OEM(s).must be uploaded.	Attach Proof
21.	Copy of NIT duly signed and stamped by the bidder on all pages Must be uploaded.	Upload

Appendix “C”

Furniture Specification

General Requirements

1. The drawings, figures & sketches given in this catalogue are not to scale.
2. Dimensions shall be read in metric unit only.
3. tolerances in dimensions are permissible as follows, if not specified:
 - a. In overall size ± 5 mm.
 - b. In thickness of pipe & sheets etc. as per relevant Indian Standard
4. Welding of pipe structures and MS sheets shall be done by gas welding only and on heavy sections by arc welding.
5. Painting or powder coated on steel sections:
 - a. Surface finishing shall be done before painting or powder coating by grinding/filing/emery paper process.
 - b. Two coat of metal primer of standard make like ASIAN/BERGER/SHALIMAR/NEROLAC shall be applied after proper putty applied on the surface and over it one under coat and the final coat of superior quality synthetic enamel paint of standard makes like ASIAN/BERGER/SHALIMAR/NEROLAC should be applied in T A Grey/Light Grey/SC Grey Sheds and olive green for outs.

- c. The whole consignment of a supply order shall be paid in one shed only.
6. The colour/shed of laminate shall be approved by Consignee, if desired.
 7. Wherever required hmr Pre-laminated Medium Density Fibre Board of 18mm/25mm thick (ISI mark)
 8. If the consignee demands any special quality of laminate, etc. other than those specified the same can be provided only after prior approval.
 9. Minor deviations from specifications. In order to improve strength/finish & comfort of the product or due to non-availability of particular material can be allowed at the discretion of NIEPMD.
 10. Wherever specified/required, good quality chrome plating on the steel section/components shall be provided. Two years replacement guarantee for chrome plated components/parts is to be given by the supplier. Wherever necessary welding riveting pressing. Folding shall be done properly.
 11. Finishing & workmanship in the product is of prime importance and must be of good quality.
 12. The supplier shall ensure that the product is manufactured as per specification and all the fitting/accessories used are of standard quality, wherever not specified. All the Table Drawer are to be provide with reputed make sliding channel arrangement. Good quality Bakelite handle as shown in Drawing.
 13. Teak wood used in the furniture shall be seasoned wood with major defects, like dead knots with through hole, wide cracks etc. shall not be used. Clear Poly Urethane lacquer polish shall be done on all wooden items.
 14. Wherever necessary good quality plastic milky white shoe`s are to be used.
 15. **Warrantee:** One year from date of delivery to consignee.

If supply of sub-standard product with/without manufacturing defect is observed even after supply. The supplier shall repair/replace the defective product free of cost, during warrantee period within one week period.

16. (A) if any dimensional discrepancy with respect to drawing and specifications due to calculation/printing mistake/any error is observed, the same may please be brought to the notice of NIEPMD before opening of tender.
- (B) If any dimensional discrepancy is observed during manufacturing ,the Same may be communicated to the purchase officer, NIEPMD immediately in writing.
- (C) Wherever not mentioned. Standard manufacturing practice is to be adopted.

COMPUTER PRINTER TABLE

Size: L910xW610xH728 mm

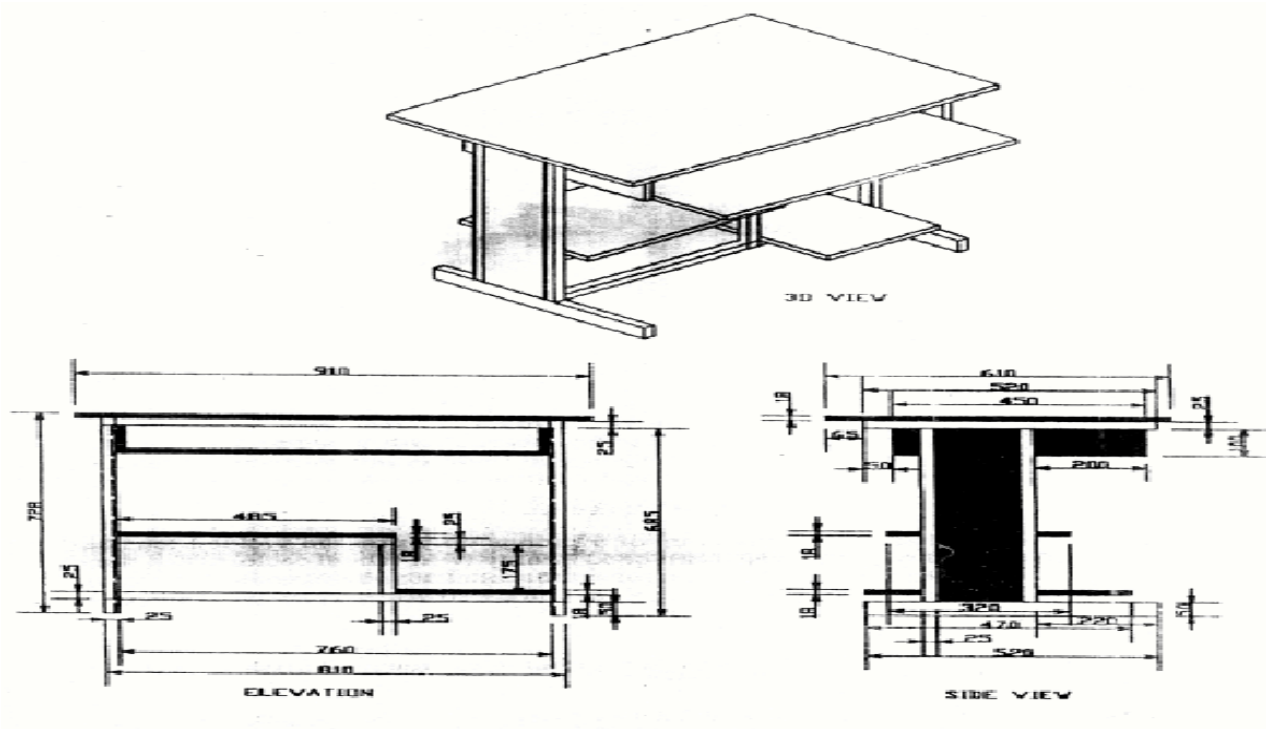

1. The computer table shall be as per figure no03.
2. Top: Size 910x610mm made of 18 mm thick pre-laminated HMR grade particle board ISI marked (IS:12823).Top shall be firmlyscrewedon25x25x2mmsquarepipeframeasshown in figure.
3. Upper side of pre-laminated board shall be in natural teak shade while the bottom side shall be white//cream shade.
4. Theedgesofthetopshallbesealedwithbeadingof18mmhalfroundteakwood with varnish finishing.
5. Sliding key board tray: A Sliding key board tray shall be madeof18mm pre-laminated particle board of size 724x450mm. The gap between top an tray shall be 100 mm.
6. Key board tray shall slide smoothly on sliding telescopic channel duly powder coated.
7. ThestorageshelfforCVT.Astorageshelfmadeof18mmparticleboardshallbe as shown in figure.
8. A CPU shelf shall be provided made of 18 mm pre laminated HMR particle board ISI mark of size 225x470mm as shown in figure.
9. Steel structure: The rigid steel structure shall consist of two nos. rectangular base pipes of size 50x25x2 mm about 520mm length placed along the width on verticalpipesofsize25x25x2mmshallbe welded for fixing up of side panels .A Supporting frame of 25x25x2 mm square pipe shall be welded on the top of pipes for the side panels as shown for supporting the top of the table. The base pipe shall be provided with adjustable shoes 2 nos. on each side.
10. Painting; complete frame work of pipes shall be powder coated.

EXECUTIVE TABLE

OVERALL SIZE : (L)1525 X (W) 900 (H) 750 mm.

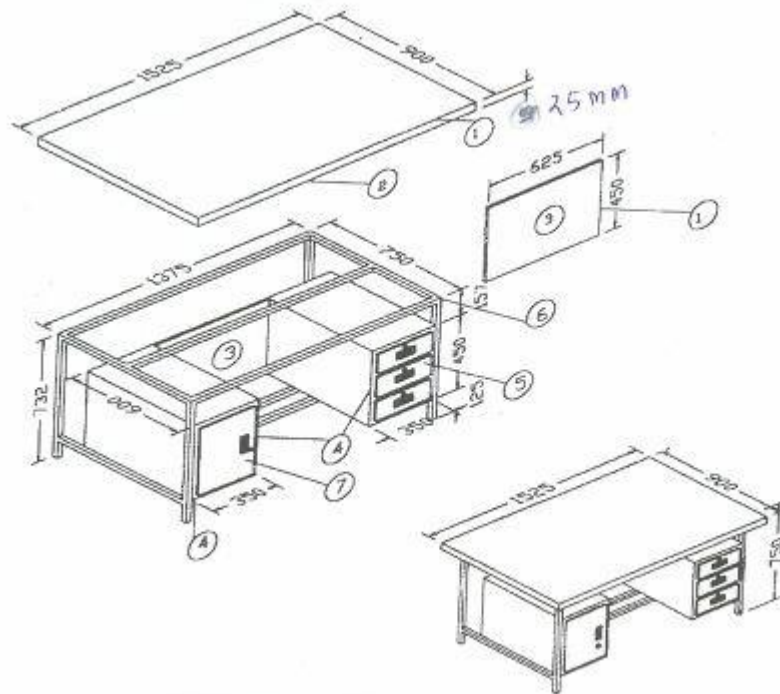

MATERIAL DETAILS :-

TABLETOP

:- 25mm THK. ISI Marked HMR Pre Laminated MDF Board IS-14587-1998. With up to date amendment

1. LIPPING

:- Teak wood half round 50mm wide, supported from inside by Jungle wood **50 mm x 25mm.** (Not shown in fig.)

2. PANNEL

:- Two folded edge CR sheet 1.2mm thick Confirming to IS-513.

3. DRAWER BOX 513.CUBOARD

:- CR sheet 1.2mm thick Confirming to IS-513. size 600(D)x350(W)x450mm(H).

4. DRAWER SIZE

:- 500(L)x100mm(d) Minimum. (3Nos)

5. FRAME & STRUCTURE

:- ERW Square pipe 25x25x2 mm in size 1375(L)x750(W)x732(H)mm.

6. CUPBOARD 513.SHUTTER

:- BOX TYPE made of 1.2mm MS sheet Confirming to IS-

7. FOOTREST

:- ERW square pipe 25x25x2mm in full length and gap between Two pipes approx. 85.mm.

8. Also refer "General Requirements."

Clerical- TABEL

OVERALL SIZE : (L)1220 X (W) 600 (H) 750 mm

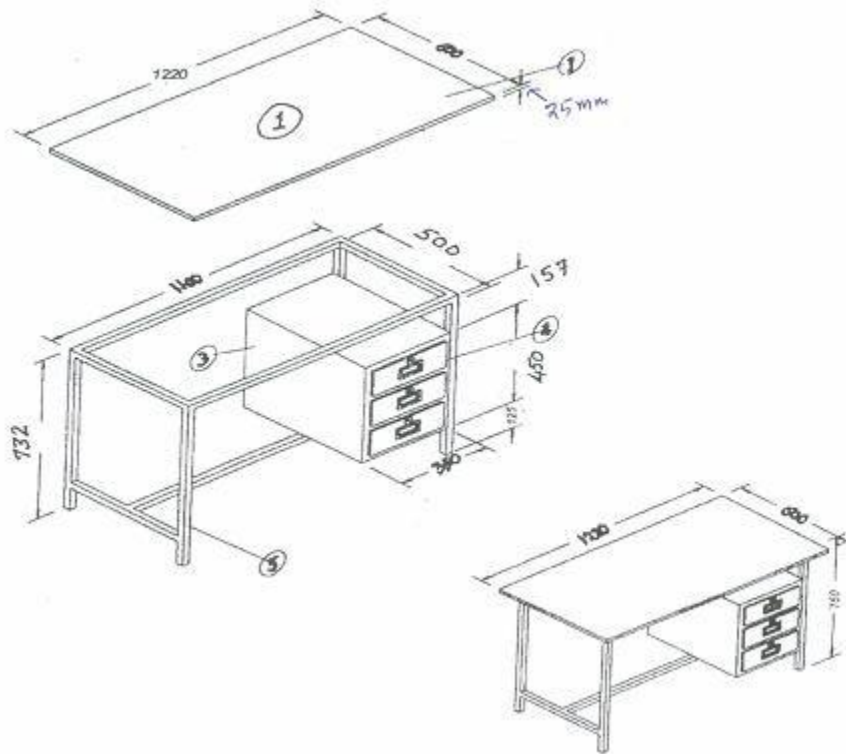

MATERIALDETAILS:-

- | | |
|--|--|
| 1. 1. TABELTOP | :- 25mm THK. ISI Marked Pre Laminated HMR Board IS-14587-1998. With up to date amendment |
| 2. LIPPING | :- Teak wood half round 25mmwide. |
| 3. DRAWERBOX /
513.CUBOARD | :- CR sheet 1.2 mm thick ConfirmingtoIS-500(D)x350(W)x450(H)mm |
| 4. DRAWERSIZE | :- 450(L)x 100mm (D)Minimum. |
| 5. FRAME&STRUCTURE | :- ERW Square pipe 25x25x 2mm
in size 1100(L)x500(W)x732(H) mm. |
| 6. FOOTREST | :-ERW square pipe 25x25x2mm in full length. |
| 7. Also refer " General Requirements." | |
|] | |

ALL STEEL DUAL DESK

2 seater Desk-cum-Bench (as per drawing)

4. Desk Size 1000 x 400 x 18mm, Bench 1000 x 330 x 18mm and Back Rest 1000x200x18mm
5. Ergonomically Designed Integrated two seater with desk. The bench and desk should have rigid steel frame 2mm thickness; manufacturers preferred are T.I, Tata and Apollo. The rigid steel frame should be perfectly fixed with seating and desk top.
6. Durable laminated top, seat & back with rounded edges for safety (post-formed laminate).The desk seating & back is to be made of high quality 18mm thick BWR grade plywood with post forming finishing.
NOTE: Options considered in the bid to be provided as samples for the same furniture.
7. All MDF to be have molded edges and other edges should be PVC taped. The preferred color of the board should be 'cherry'.
8. Provision should be made for shelf / storage in perforated metal 1.6mm for storing a few books at the bottom of the seat.
9. All steel tube ends should be closed using steel welding. All welds should be ground & finished.
10. All the steel parts should be powder coated with 'Basalt Grey tex' color.
11. All bushes/levelers of high quality nylon or other approved material. Also should be with high impact resistance & vibration resistance.
12. The specifications of materials used should be provided as per drawing. Better value elements can be added to the furniture sample, subject to the design being accepted.
13. The samples should be delivered within ten days which will be tested for strength, breakage, quality of materials & adherence to specifications mentioned.

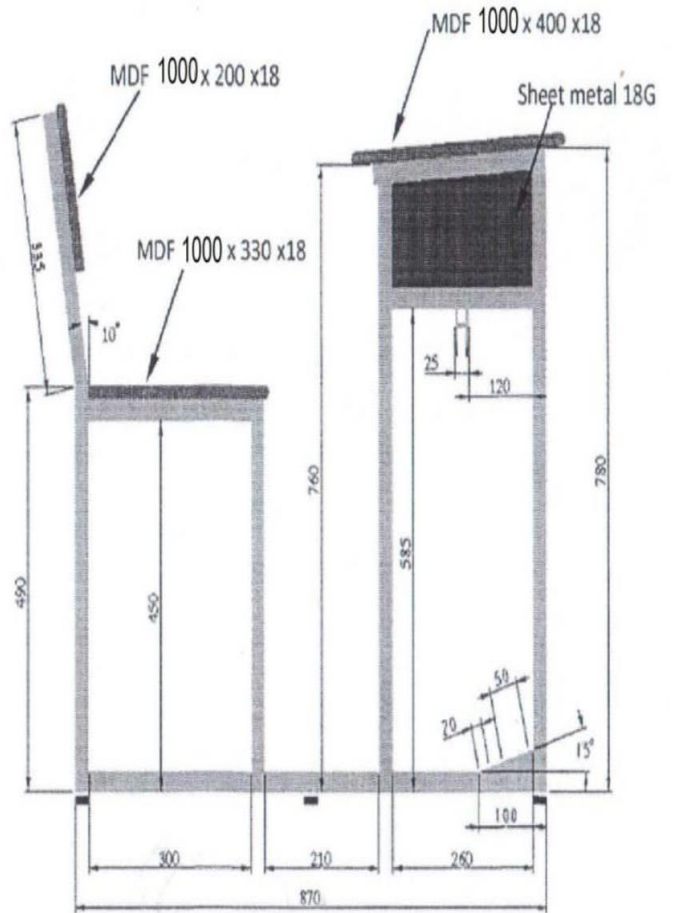
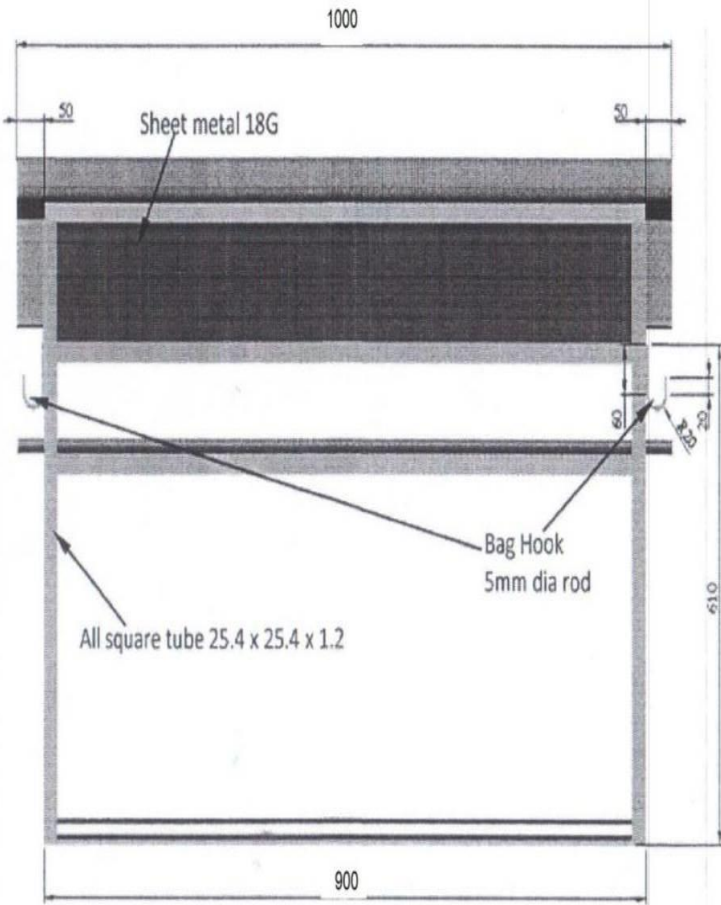

OFFICE CHAIR (CONTINUOUS ARM)
OVERALL SIZE : (H) 900/455* (W) 500*(D) 560mm.

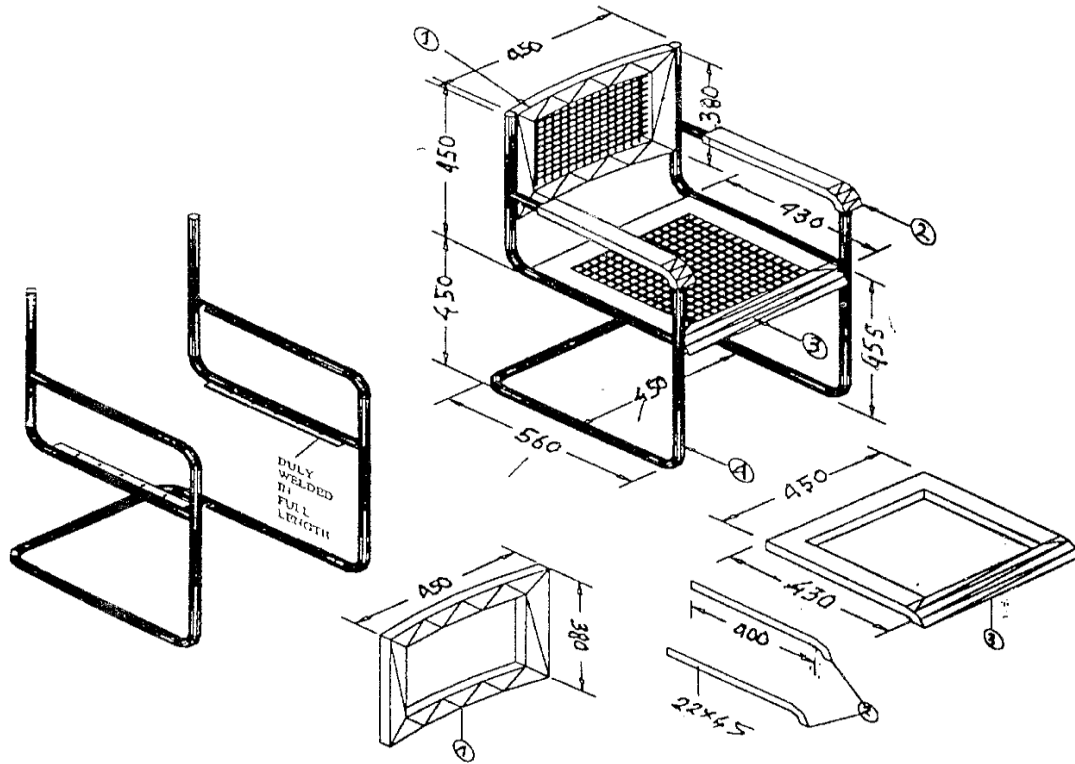

MATERIALDETAIL:-

1. FRAME :-ERW round pipe 25mmdia x 2.0mm thick in one piece.
2. SEAT&BACK :- Teak wood section 45x22mm duly polished Shining black enamel. Paint .the best quality high strength Nylon/Plastic Cane wire shall be used. The 6 no. of cane wire Shall be passed in each hole of back and seat. In seat, front section to be doubled and rounded to As shown in the fig
3. FITTING :-Seat shall be fitted over flat size 25x4 mm thick in depth wise of frame on both side with minimum 3 no. screws on each side. Back rest shall be fitted by round head steel screws 3 ns. On each side.
4. WOODENHANDLE :- Size 25x45x400mm made of teak wood with front curve having under side grooved profile matching with pipe to be fitted with 3no.. screw on each side from under side, Handles shall be duly polished and Painted with shining black enamel paint.
5. Also refer "General Requirement".

OFFICE CHAIR WITHOUT ARM
OVERALL SIZE : (H) 900/455 x (W) 500 x (D) 530mm.

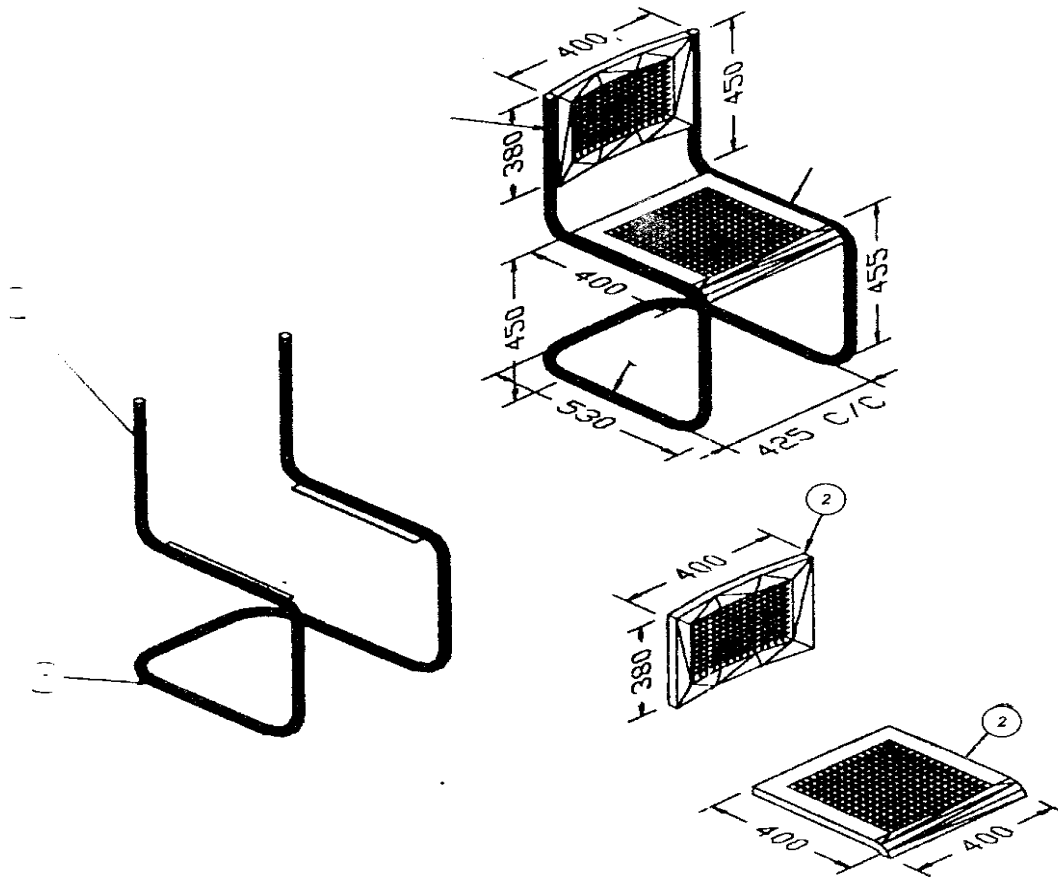

MATERIALDETAIL:-

- | | |
|---------------------------------------|--|
| 1. FRAME | :-ERW round pipe 25mmdia x 2.0mm thick in one piece. |
| 2. SEAT&BACK | :- Teak wood section 45 x 22mm.Duly polished shining black enamel. Paint .the best quality high strength Nylon/Plastic Cane wire shall be used. The 6 no. of cane wire Shall be passed in each hole of back and seat. In seat, front section to be doubled and rounded to As shown in the fig. |
| 3. FITTING | :-Seat shall be fitted over flate size 25x4mmthickin depth wise of frame on both side with minimum 3 no. screws on each side. Back rest shall befitted by round head steel screws 3 ns. On each side. |
| .4. Also refer “General Requirement”. | |

REVOLVING CHAIR HIGH BACK

W650 x D650 x H1050 / 1140 mm



1. Overall size : Width **650mm** ← Without castors
Depth **650mm** ←
Height 1050 to 1140mm
Adjustability of seat height 440 to 530mm

2. Seat size : 500x500mm approx.

3. Back size 500x610 (H) approx.

4. Material:

Seat and back should be made up of 12mm thick hot pressed plywood upholstered with fabric and molded Polyurethane foam (60mm thick. With density 50-55), together with molded ABS seat and back covers. The back foam is designed with contoured lumbar support for extra comfort.

5. The armrest should be one piece and made of black integral skin polyurethane and reinforced with MS insert and scratch and weather resistant.

6. Castors : The twin wheel castors should be injection molded in black Nylon.

7. Pedestal Assy : The pedestal should be injection moulded in black 30% glass filled Nylon with gas lift mechanism.

8. Upholstery: The seats and backs are to be covered with superior quality fabric.

9. Finish: All steel components are to be painted after proper anti corrosion pretreatment of surface.

10. The overall appearance of the product shall be as per photograph.

Revolving Mid back Chair



SPECIFICATION. 1) SEAT/BACK ASSEMBLY: The seat is made up of insert molded Polyurethane Foam upholstered with foam laminated mesh fabric. The insert molded foam is assembled over a load bearing plastic seat cover. The back is made up of two piece injection molded frame. The inner frame is upholstered with mesh fabric and mounted on the main assembly. The back has adjustable lumbar support for achieving comfortable seating posture. Sub Assembly Seat size = 52.5 cm (+ 3cm) Width, 51 cm (+ 2cm) Depth. Sub Assembly Back size=48.5 cm (+ 2cm) Max Width, 62 cm ht (+ 3cm). Effective Back Ht from Seat = 57 cm (+ 3cm)

2)POLYURETHANE FOAM: The polyurethane foam for seat is molded with density = 75 ± 4 kg/m³ and Hardness = 34 ± 4 .

3) FRONT PIVOT SYNCHRO MECHANISM: The mechanism is designed with the following features: 360 degrees revolving type - Single point control - Front pivot for tilt with feet resting on ground ensuring more comfort - Tilt tension adjustment – 3 position locking with anti-shock feature.

4)CONNECTING SPINE BRACKET: spine bracket is made of Aluminium diecast piece connecting back with mechanism.

5) PNEUMATIC HEIGHT ADJUSTMENT: The pneumatic height adjustment has an adjustment of 8.5 (+ 1cm) cm.

6) PEDESTAL ASSEMBLY: Pedestal is made of Die cast Aluminium fitted with 5 nos. twin wheel castors (castor wheel dia. 6.0 + 2cm). The pedestal is 65.0cm + 3cm. Pitch center dia. (71.0 cm + 3cm with castors).

TWIN WHEEL CASTORS: The twin wheel castors are injection molded in Nylon

COMPUTER CHAIR WITH HANDLES



1. Chair shall be as shown in the figure.
2. Seat size shall be 430x430 mm on 10 mm thick molded comm. ply with 60 mm thick 40 density molded PU foam.
3. Back rest size shall be 430x430 mm on 10 mm thick molded comm. ply with 40 mm thick 32 density molded PU foam covered with tapestry. The height of back rest shall be 900 & 500 mm for top and bottom edges respectively. The back rest shall be provided with lifting arrangement on flatiron & helical spring.
4. Two nos. suitable PU handles shall be proved.
5. The base stand should be made up of 5 prongs durly pressed welded togethercentrallywithapedestalbushwithgoodqualitytwinwheelcastors.Thestandan dother metal parts excluding central spindle shall be power coated complete steel structure shall be pretreated and power coated with minimum thickness of 60 microns coating.
6. ACentralspindleof25mmdiarodwithoutthreadsshallbeprovidedwithrevolving arrangement. The adjustable height of chair shall be from 530 to 570mm.
7. A good quality tapestry cloth shall be provided on seat & back in attractive colour/ shade.

4 DRAWER LIBRARY STEEL BOOK CASE

OVERALL SIZE : (H) 1675x(W) 840x (D) 380mm.

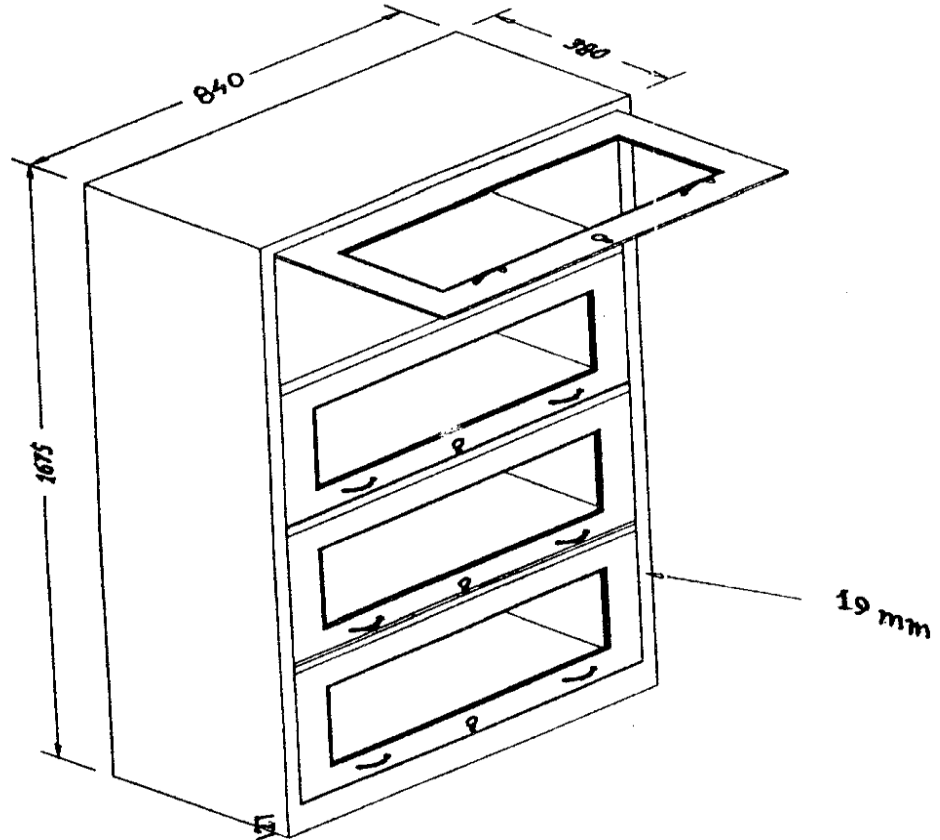

MATERIAL DETAILS :-

The Design of this steel Bookcase shall be as shown above.

Sheet CR prime 1.2 mm thick Confirming to IS-513 with latest Amendment

Compartment- 4 no.

Six leaver locks of high quality in each shutter operated by one key, supplied with key ring.

Chrome plated, metallic handles two no's, on each shutter from outside.

Plain glass, 4mm thick in each shutter fitted in suitable frame from inside.

Shutter sliding on ball bearing, two nos. in each door with suitable system / double roller system.

One additional plate of 127mm highx830mm width shall be provided on lower side.

Please refer "General Requirement".

STEEL FILING CABINET (Four Drawers)
OVERALL SIZE : (H) 1380x(W) 470x (D) 700mm.

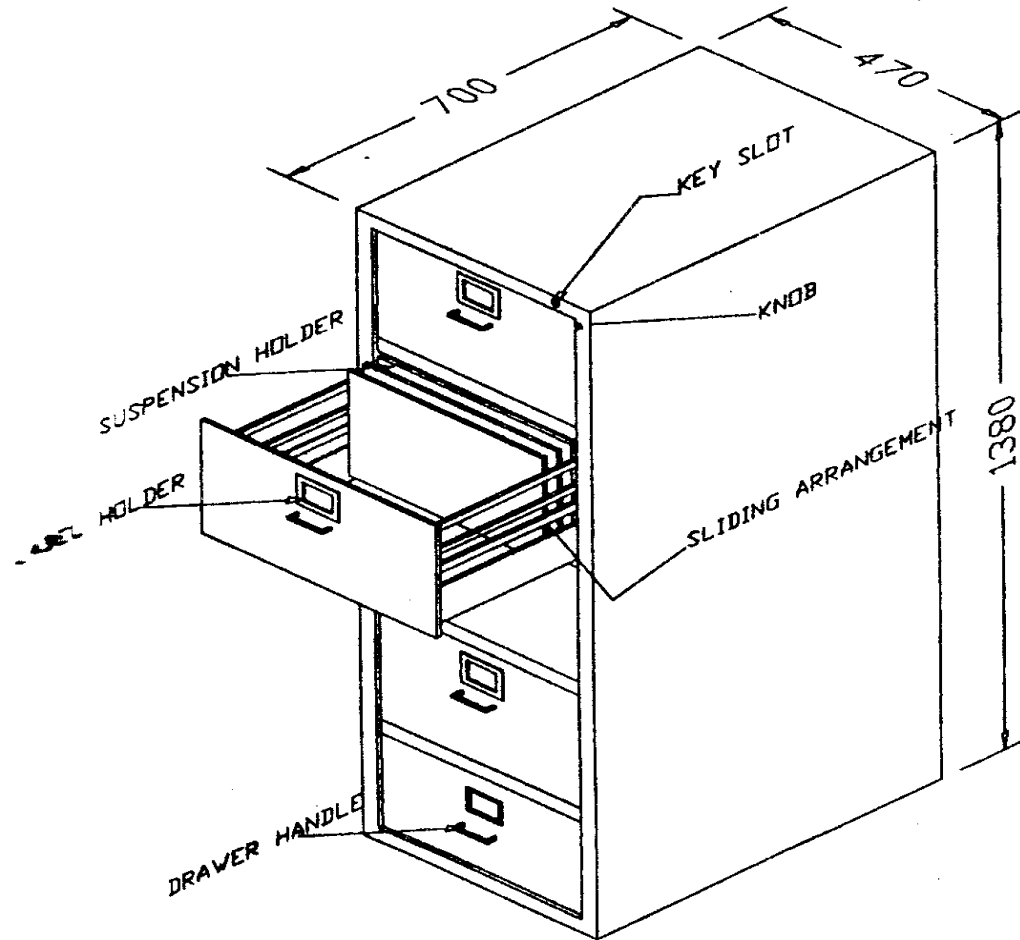

MATERIAL DETAILS:-

The Design of this steel filing cabinet shall be as shown above.
Complete cabinet shall be made of 1.2mm CR sheet conforming to IS-513
Locks: 6 Lever of high quality shall be of automatic unit type push button.
Telescopic/sliding arrangement shall be provided for drawers.
Suitable size channel shall be provided throughout the depth in 1.60mm thick sheet.
One nickel label frame and a nickel/chrome plated handle shall be provided on each drawer.
Approx 12mm gap between each drawers shall be provided.
Suspension holders shall not be provided with the cabinet.
Please refer "General Requirement".

STEEL ALMIRAH

OVERALL SIZE : (H) 1980 x (W) 915 x (D) 480mm.

1.0mm CR Thick Sheet.

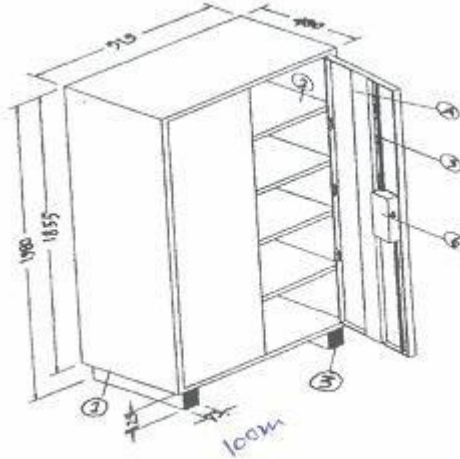

1. Body 2. Shelf 3. Legs 4. Door stiffener 5. Lever Rod 6. Door Handle

MATERIAL DETAILS:-

1. The overall design and appearance of cabinet shall be as per figure.
1. The CR Sheet used shall be of prime quality, Confirming to IS-513 and thickness 1.2 mm
2. Each shelf be formed such the edges are bend two times at right angle, first bend 30mm and second bend 8mm.
3. Door stiffener frame inside to its full height in top hat section size 100mm width.
4. Lever rod shall be of MS 12mm round/square bar, or 10mm bright bar.
5. Size of hinges shall be 75mm length x 1.6mm thk.
6. Brackets shall be made of 1.6 mm of CR sheet, riveted or bolted on each side of hinges.
7. Machine made lever plate (patla) with brass bush of good quality or machine made six lever type patla. Patla shall be covered by box covered by box over fitted with round head screws.
8. For locking brass body Godrej type cabinet lock or cabinet lock 6 lever die cast zinc alloy body of size (h) 65 x (W) 50mm fitted on four screws or "GRACE" LOCK. Keys in duplicate with key rings shall provided.
9. Metallic key cover electroplated nickel/chrome on front side of the door shall be provided.
10. For door, die cast chrome plated handle fitted with washer and double nut.
11. Leg height shall be 125 mm x 100 mm.
12. Also refer "General Requirement".

CABINET PLAIN MINI SIZE

**OVERALL SIZE: (H) 915 x (W) 610 x (D) 380 mm.
1.0mm CR Thk Sheet.**

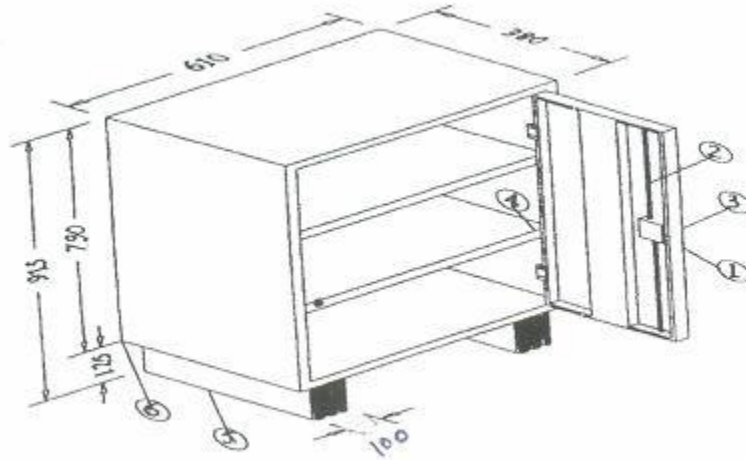

1) Door stiffener 2)Lever Rod & Plate 3)Door Handle 4)Shelf 5)Legs 6)Body
MATERIAL DETAILS:-

1. The overall design and appearance of cabinet shall be as per figure.
2. The CR Sheet used shall be of prime quality, Confirming to IS-513 and thickness 1.2 mm
3. Each shelf shall be formed such the edges are bend two times at right angle, first bend 30mm and second bend 8mm.
4. Door stiffener frame inside to its full height in top hat section size 100mm width.
5. Lever rod shall be of Ms 12mm round/square bar, or 10mm bright bar.
6. Size of hinges shall be 75mm length x 1.6mm thk.
7. Brackets shall be made of 1.6 mm of CR sheet, riveted or bolted on each side of hinges.
8. Machine made lever plate (patla) with brass bush of good quality or machine made six lever type. Patla shall be covered by box over fitted with round head screws.
9. For locking brass body Godrej type cabinet lock or cabinet lock 6 lever die cast zinc alloy body of size (H) 65 x (W) 50mm fitted on four screws or "GRACE" lock. Keys in duplicate with key rings shall provided.
10. Metallic key cover electroplated nickel/chrome on front side of the door shall be provided.
11. For door, die cast chrome plated handle fitted with washer and double nut.
12. Leg height shall be 125mm x 100 mm.
13. Powder coated finishing after Seven Tank process.
14. Also refer "General Requirement".

CABINET WARDROBE

OVERALL SIZE (H) 1980 x (W) 900 x (D) 560mm.

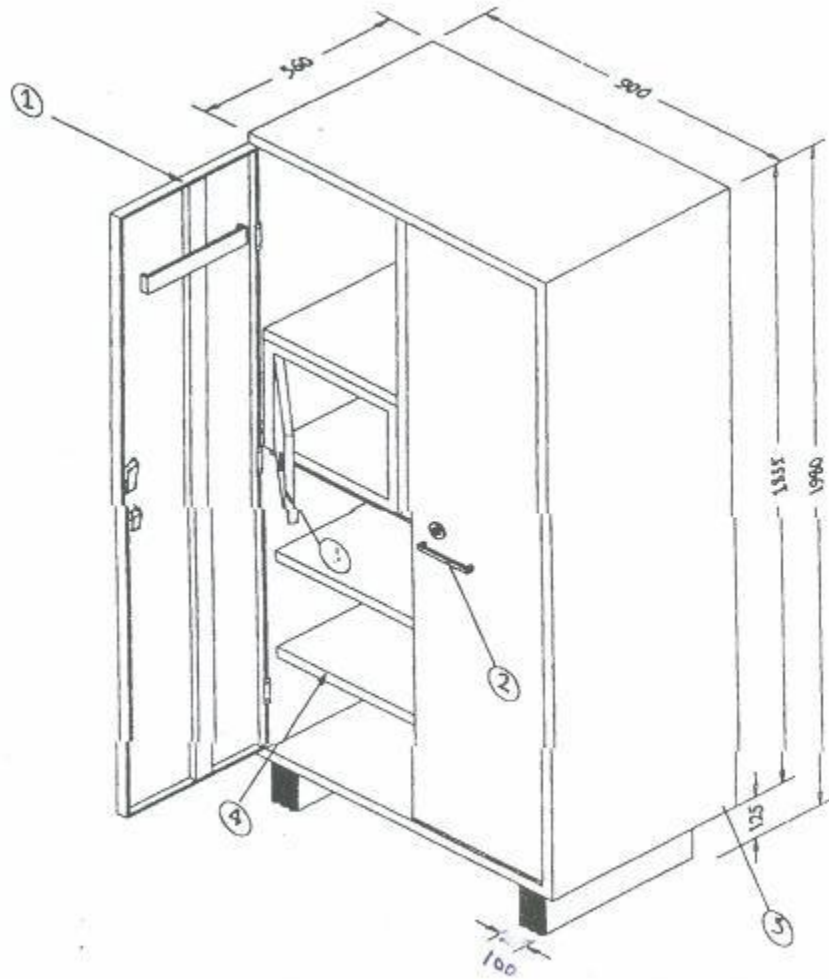

NOTE :- Detail are given in the Annexure

1. Door Stiffener 2. Door Handle 3. Locker 4. Shelf 5. Body

Annexure

The overall design and appearance of cabinets shall be as per their respective figure.

The CR sheet used shall be of prime quality Confirming to IS-513 Each shelf shall be formed such the edges are bend two times at right angle, first bend 30mm and second bend 8mm.

Size of hinges shall be 75mm length x 1.6mm thick.

Brackets shall be made of 1.6mm of MS. sheet, riveted or bolted on each side of hinges.

Machine made lever plate (patla) withy brass bush of good quality or machine made six lever type Patla . Patla shall be covered by box covered by box over fitted with round head screws.

Metallic key cover electroplated nickel/chrome on fount side of the door shall be

provided. For door, die cast chrome plated handle ritted with washer and double nut.

- Top shelf of cabinet shall be fitted at 914 mm from top. This portion called wardrobe shall be provide with partition in full length. On left side of wardrobe one locker with 250mm height. Locker shall be provided with box type door with die cast chrome plated handle. Lock shall be plate type with 150mm sliding plate/25 mm pin rod/ 30mm plate sliding arrangement.
- On the right side of wardrobe one hanger pipe of 18x1.2mm thick chrome plated shall be provided.
- One mirror (1200x300mm) of good quality ATUL/modi make, fitted on left door from outside in pressed steel section.
- Leg height shall be 125x100 mm.
- Powder coated finishing after Seven Tank process.
- Please refer "General requirements."

Type	Size mm (HxWxD)	Sheet	No. of Hinges & Brackets	Shelf No. & Depth
CABINETPLAIN	1980x915x480	1.00mm	6	4 nos.x/400mm
CABINETPLAIN	1270x760x430	1.00mm	4	3 nos.x/355mm
CABINETPLAIN	915x610x380	1.00mm	2	2 nos.x/330mm
WARDROBE	1980X900X560	1.00mm	6	3 nos.x/500mm

GLASS DOOR DISPLAY CABINET
OVERALL SIZE : (H)1980 x (w) 900 x (D) 480mm

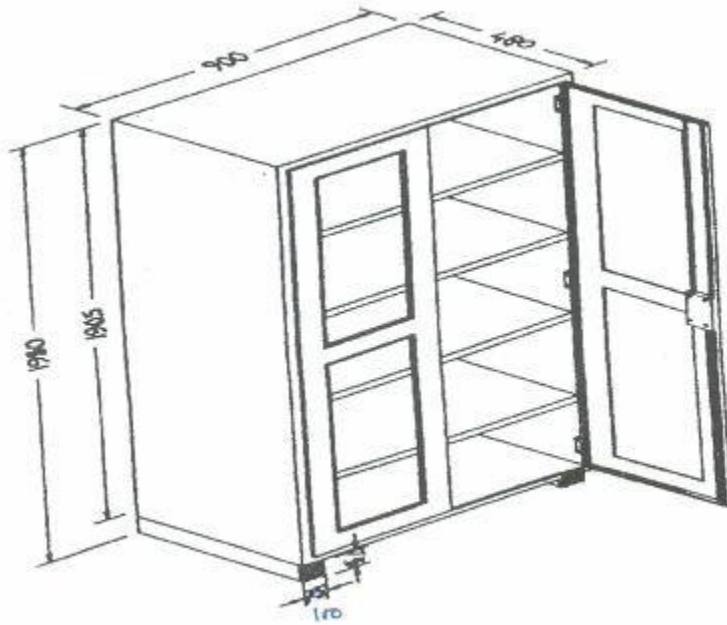

MATERIAL DETAILS :-

1. The design of Glass door cabinet shall be as above in the figure.
2. CR sheet 1.2mm thick Confirming toIS-513.
3. Shelf 4 nos. forming five compartments. Edge first bending 30mm and second edge bend 8mm and depth of shelf400mm.
4. Plain glass 5mmthick on each side of door with suitable cushion pads. The glasses shall fit in an additional frame of top section which is fixed to shutter frame from inside.
5. Machine made lever plate (Patla) with brass bush or machine made six lever type patla which is fixed in height wise or width wise of cabinet. Lever rod 10mmround.
6. Hinges and brackets three nos. on each side size 75Hx1.60mm thick mm and 1.6mm thick sheet for brackets.
7. Die cast handle door metallic, nickel;/chrome plate with double nut. Key cover of best quality metallic ,nickel/chrome.
8. Lock-Godrej Type cabinet lock / Grace 6Lever.
9. Leg 75 x 75mm duly welded are riveted.
10. Powder coated finishing after Seven Tank process.
11. Please refer "General Requirements".

BOOK RACK

Size : 900 mm x 600 mm x 1800 mm H

Back to Back

Material : 25 mm & 18 mm thick HMR pre-laminated board with 2 mm thick CR sheets

Metal parts are powder coated



New Arrivals stand / Magazine Stand

Four side Revolving 360 degree, 4 sided 5 Segments New Arrivals stand. Unit manual operated. Main unit size 25"Lx25"Wx54"H. Made of MFC CPL GLUNG Chip Board with Both Side Laminated Beech/Oak Finish. Floor Base Mounted on 76mm Rubber Castor. Top Part and Base Part Attached with the Help of 12" DIA Disc Bearing steel plate for smooth 360 degree Rotation. Base unit size 4" H x 25" W x 25" L



Periodicals Display Rack

Size: 1800 mm (W) x 450 mm (D) x 1830 mm (H). Providing & Fixing Periodical Display Rack for magazine/ catalogues with body made of CRCA steel duly powder coated and vertical sides made of 25mm pre-laminated particleboard with all exposed edges sealed with 2mm thick PVC edge banding tape. Display Rack has top sliding shutter with provision to keep 30 magazines in Each Rack face behind shutters made up of CRCA steel duly powder coated.



6 Seater Reading Tables for Library

1200mm W x 900mm D x 740mm D, Worktop made from 25mm thick HMR grade PLB with post form finishing. Under structure is 50 x 50mm with 2mm thick MS C - frame supporting the top. Legs are made of 50 x 50mm with 2mm MS ERW tube. or near equivalent with Powder coated finishing after Seven Tank process.



Reading Chairs

Size: 51cm W x 60cm D x 82cm H, Seat / back are made up of 1.0cm thick hot pressed water resistant, commercial plywood, upholstered with PU foam and fabric (PU foam is moulded with density = 45 +/- kg/m³ and hardness = 20 +/- 2) . Size of back 42cm W x 27cm H, seat size : 42cm W x 42cm D. Under structure assembly is a mainframe made of dia 2.54cm x 14 BG MES RW tube and a welded leg tube made of dia 2.54cm x 18 BG MS ERW tube to form the complete assembly which is black powder coated. or near equivalent



Chair with writing pad

Size: 54cm W x 77cm D x 81cm H, The seat and back shall be 1.6mm thickness perforated sheet. The under structure assembly is a welded frame made of dia19mm x 1.2mm thick MS ERW tube and black powder coated. Desklet is made of 19mm thick plywood with melamine finish all around. or near equivalent



Best Stainless Steel Waiting Chair

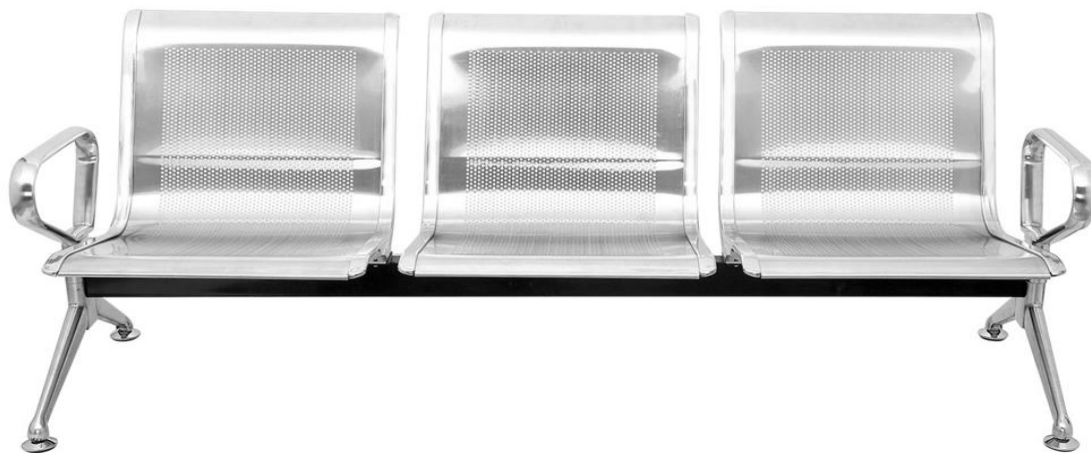

- Seat width: each Chair is 52 cms
- Seat Bent Line : 90cm,
- Arm Length: 37cm, Width: 31cm, High: 4cm,
- Leg Length: 54cm, high: 22cm without SS base Height.
- BEAM: 1.7mm Thickness with Durable Screw Tube;
- Total Out to Out Width: 180cms
- Height: 78cms
- Depth: 68cms
- Weight: 35-36Kgs
- Collection: Perforated Stainless Steel Chairs, 3 Seater Steel chairs, Steel Waiting room Chairs.
- All Measurements Subject to tolerance Of 2%

INDUSTRIAL LOCKER CABINET (9 Lockers)

OVERALL SIZE: (H)1800 x (W) 900x (D) 380mm.

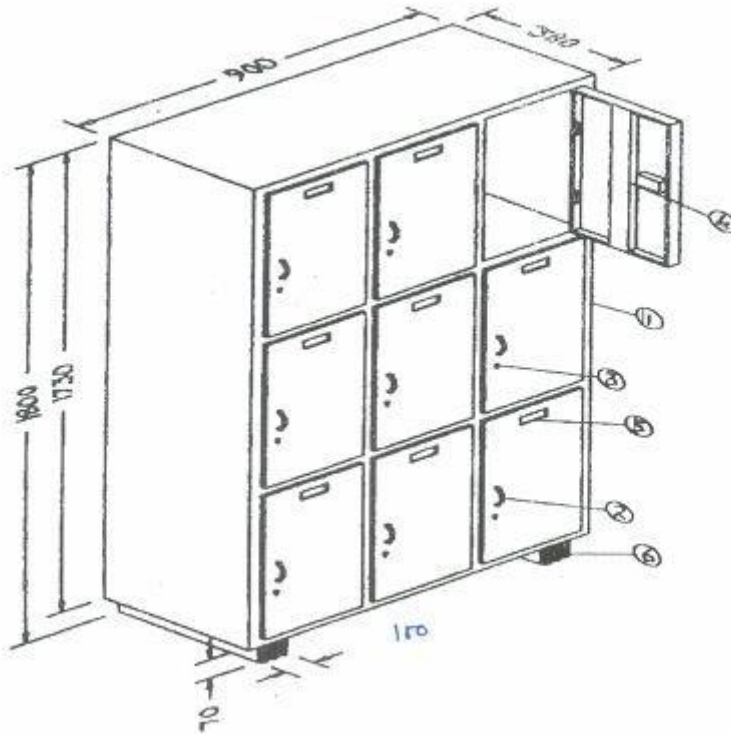

1. Body 1.2 mm CR SHEET Confirming to IS-513
3. Key hole, 4. Door stiffener. 5. Label Holder

2. Handle Nickel/ Chrome plated.
6. Leg.

MATERIALDETAILS:-

1. The design of this industrial locker cabinet having 9 locker shall be as shown above.
2. Six of locker doors shall be 260x550mm height.
3. Separate locking system in each locker. Locks of 6 lever of good quality with duplicate keys & Key rings.
4. Label Holder Nickel/chrome plated or Aluminum on each door.
5. Two hinges 50x1.0mm thick in each door, along with two brackets of 1.25mm thick.
6. Door stiffener in side to its full height in top hat section of suitable size.
7. Please refer " General Requirements".

INDUSTRIAL LOCKER CABINET (16 Lockers)

OVERALL SIZE: (H)1800 x (W) 900x (D) 380mm.

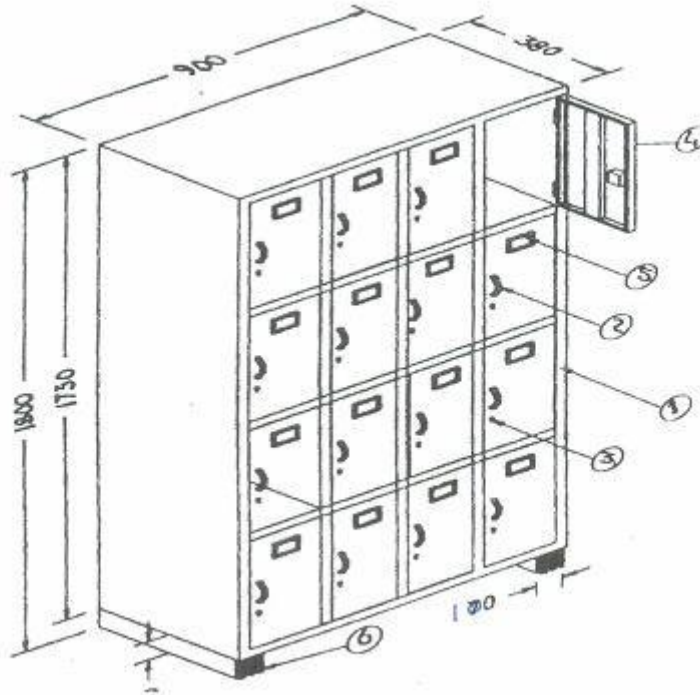

- 1. Body 1.2mm CR SHEET Confirming to IS-513 2. Handle Nickel/ Chrome plated.
3. Key hole. 4. Door stiffener. 5. Label Holder 6. Leg.**

METERIALDETAILS:----

1. The design of this industrial locker cabinet having 16 locker shall be as shown above. and fabricated 1.2mm CRCA sheet, with powder coated finishing Size of licker doors shall be 260x450mm height.

Separate locking system in each locker. Locks of 6 lever of good quality with duplicate keys & Key rings.

Label Holder Nickel/chrome plated or Aluminum on each door.

Two hinges 50x1.0mm thick in each door, align with two brackets of 1.25mm thick.

Door stiffener in side to its full height in top hat section of suitable size.

Please refer " General Requirements ".

Sofa Set (3+1+1) Seater

The Structure will be made in solid wood and plywood wherever required. The structure shall have copper spring base with elastic belts with foam / jute covering on top. The seat shall have 32 density foam of 4 1/2" thick with fabric covering in velvet finish and or leatherite as per room decor. The body will have full fabric covering in velvet / leatherite fabric with back cushions in fiber. The size will be 54" with seating width of 22" each and sofa outer depth will be 32". The wood shall be fully treated and seasoned solid wood Sheesham. The sofa will be Three +One + One seater sofa.



TECHNICAL SPECIFICATIONS

Steel Single Cot -1830mm x 750mm x 500mm (as per drawing)

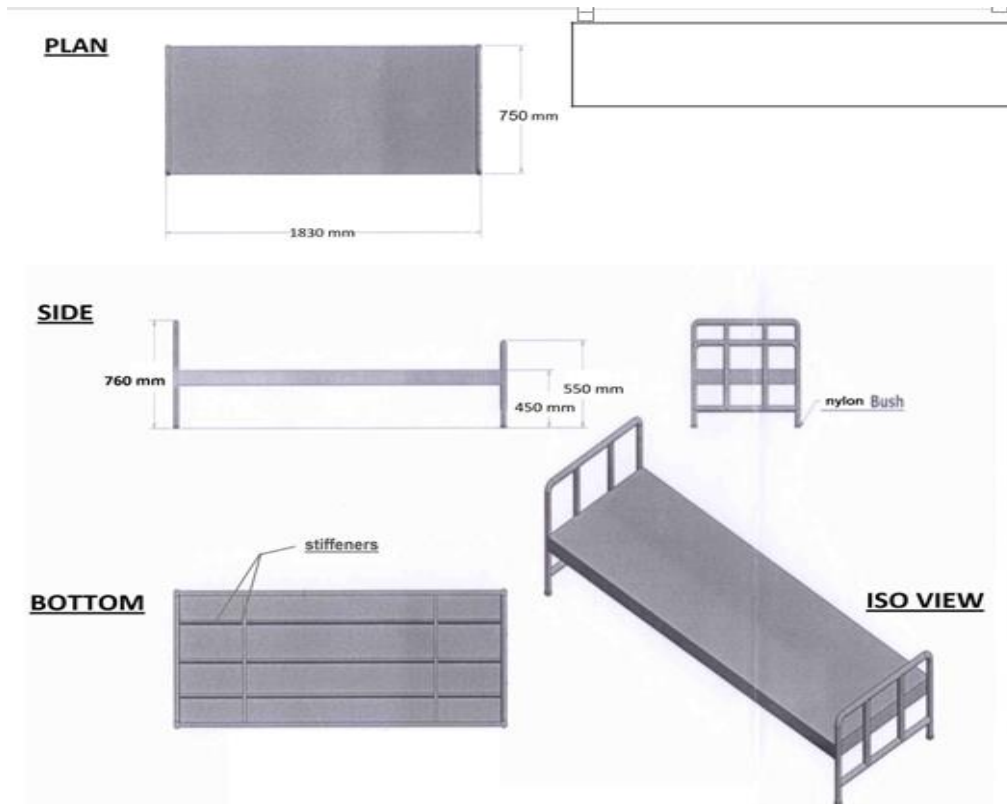

3. The top horizontal platform with 14G sheet and square frame with CRC steel pipes of 1 inch with thickness 18G steel.
 4. The rigid steel frame should be perfectly fixed/welded to the horizontal base.
 5. All the welding should be done using electro-welding process only.
 6. The overall weight of the cot should not be less than 37 kg.
 7. The horizontal base should be stiffened with appropriate longitudinal stiffeners (preferably 3-4 "V-Shape sheet") using arc welding technique & lateral stiffeners (preferably 2-3 steel pipes) to be provided under the horizontal base.
 8. The horizontal base should have an edge molding (50mm) with a plate inside.
 9. All steel components need to be given acid wash, anticorrosive treatment prior to powder coating. Preferred manufacturers of steel are T.I, TATA, APPOLO.
 10. All steel components should have powder coating of thickness greater than 60 μm .
 11. All bushes/levelers should be of high quality nylon or other approved material. Also should be with high impact resistance & vibration resistance.
- 46478
12. The specifications of materials used should be provided as per drawing. Better value elements can be added to the furniture sample, subject to the design being accepted.

MATTRESS FOR SINGLE BED

Providing and supplying mattress made up of 5" foam on top and centre supporting bonded foam with solid foam block. It offers firm support and comfort. It has single side quilting.

SIZE: .98 X 1.875 m

Make- Spinecare/Kurlon/Sleepwell or equivalent reputed brand



Door Covered Shoes Rack



Dimensions: H 25 x W 23 x D 15, Assembly: Self Assembly

Primary Material: Polypropylene (PP)

Height: 25.0 inches

Width: 23.0 inches

Depth: 15.0 inches

Teak wood dining table:

Teak wood dining table of standard size (10'x3') having frame, lipping, molding in teakwood, polished, provided with 1 mm thick matt finished mica provided over 19 mm thick good quality commercial board as approved.



Dining Chairs



Specifications: Frame made of 25mm CRC tube with chrome plating and 45mm cushion on seat and 25mm cushion on back covered with approved quality upholstery.

STUDY TABLE



- SPECIFICATIONS:** The Study Table integrated with an overhead book shelf is made of 18mm thickness pre-laminated HMR Board processing the following specifications:
1. Size of Study Table must be 3'.5" L x 2'.6" H made up of 18mm thickness pre-laminated HMR Board overhead storage and integration of both.
 2. The Table top must be ISI marked 18mm HMR board, one side laminated, front side post formed and the remaining three sides are protected with 2mm thick PVC lipping fixed with hot melt glue.
 3. The table must be equipped with a wooden drawer with the side of outer body 12"W x 18" Dx 12" H. The drawers should moves on ball telescopic slides 350mm.
 4. Lock- Ebco/Ozone
 5. Handles to be of SS. The bookshelf to be located 18" above the table, the space between the bookshelf and table top to be clad with pre-laminated HMR ISI marked 12mm thick.
 6. Provision of holder for bulb/CFL underneath the bookshelf be given. It should be completely shrouded from the eyes of reader to prevent glare.
 7. There should be a leg rest made of CRCA pipe 25x50mm of 1.2mm thickness.
 8. The swing door must be of unit having size of 12"x15" made up of 1.2mm CRCA sheet.
 9. Overhead Storage of size 42"x22"x12" [wall mounted] is to be covered from sides, back and top. The storage cabinet should be framed to maximum durability. The rack should be made from 18 thick HMR prelaminate particle board with 2 slots the top being 10" height and bottom being 12" height. The 2 slots [storage unit] to be equally portioned vertically.

STUDENT STUDY CHAIR



SPECIFICATION

1. Seat/ back shell: The sheet backshell is made up of 12 mm thick hot pressed plywood laminate with natural veneer in shade of teak. Back size: 40.5cm [W] x 40.5 cm [H], Seat size for 43 cm [W] x 39cm [D].
2. Tabular understructure : The understructure is made up of MS tube of dia19mm x 14 G thickness and black coated. It is to be fitted with black injection ferrule and support features.

Acrylic Door Covered felt notice board

1. Single Sided Notice Board with Acrylic Covered.
2. 2x3 feet, 4x3 feet, 4x 6 feet 8x3 feet board size.
3. Anodized Aluminium Frames.
4. 5mm Thick Clear Acrylic Cover
5. Board base Blue Colour Cloth with pinning surface.
6. Board is made from Ply and Soft board.



Key hanging box

No.of Keys 20 , Size of cabinet : 12 x 20
No.of Keys 30 , Size of cabinet : 16 x 20
No.of Keys 40 , Size of cabinet : 20 x 20
No.of Keys 50 , Size of cabinet : 24 x 20
No.of Keys 100 , Size of cabinet : 31 x 35



Felt Board

1. Single Sided Notice Pin Board.
2. 2x3 feet, 4x3 feet, 4x 6 feet 8x3 feet board size
3. Board base Blue Colour Cloth with pinning surface.
4. Board is made from Ply and Soft board.
5. Framed in doubled sided curved anodized aluminum section Chromium plated plastic corners with good aesthetics Chromium plated metal.



Felt Notice Boards

Combination Board

2x3 feet, 4x3 feet, 4x 6 feet 8x3 feet board size

Fabricated out of 8 mm MDF with resin white sheet for white board and 8 mm soft board covered with flannel fabric for soft board. Framed in doubled sided curved anodized aluminum section Chromium plated plastic corners with good aesthetics Chromium plated



metal.

White writing Board

Standard melamine whiteboard surface

Best for light use; extend surface life by cleaning regularly with Quartet cleaning solutions

2x3 feet, 4x3 feet, 4x 6 feet 8x3 feet board size.

Satin-finish aluminium frame matches any classroom environment

Full length marker tray and hanging system included



White Magnetic Board

Whiteboard is magnetic to hang posters, magnets and more.

Tray with protective end caps keep markers and erasers in place.

Made from tough material to resist most types of damage.

2x3 feet, 4x3 feet, 4x 6 feet 8x3 feet board size



Foot step stool single

Size-19" x 9" x 9"
20g sheet,20 x 40mm rectangle pipe 18g legs
1/2" dia cross pipe
Stainless steel



Godrej Halo High Back Chair / Revolving Visitor / Very High Back Chair

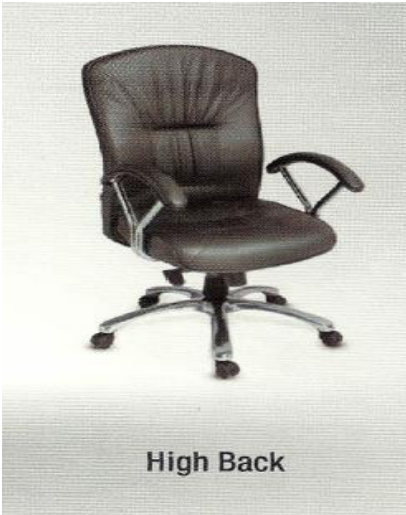

High Back

W 770 x D 770 x H 1135-1225 x SH 499-589

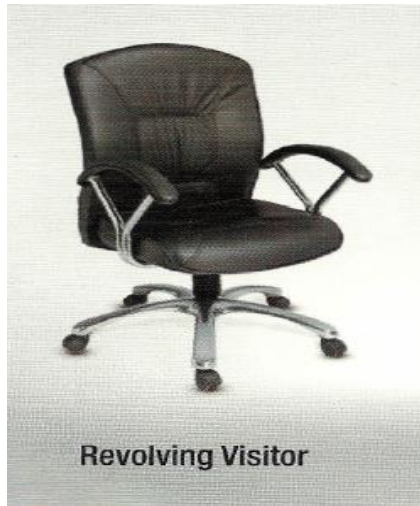

Revolving Visitor

W 770 x D 770 x H 994-1114 x SH 434-554



Very High Back

W770 x D770 x H1280-1370 x 499-589

Specification as per Godrej. Only Godrej brand will be accepted.

Godrej Push-Pull Type Optimizer 3 Portion



Specification as per Godrej. Only Godrej brand will be accepted

GREEN CLASS ROOM CHALK WRITING BOARD 4FEET X 8 FEET

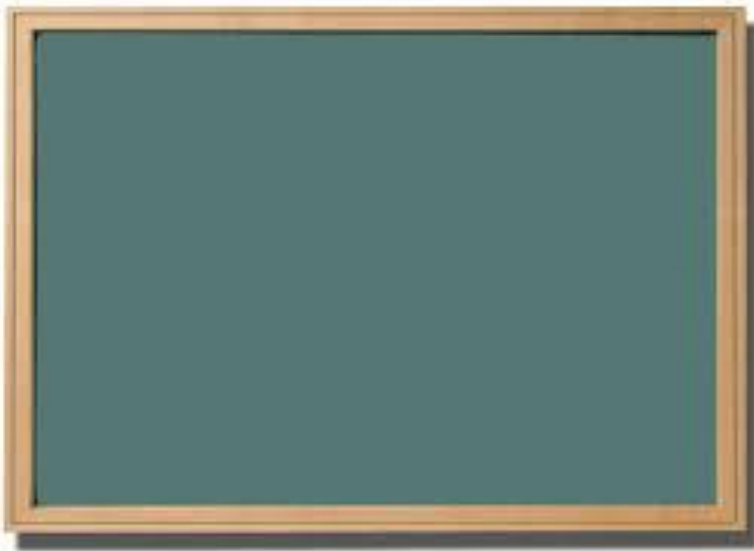

Nilkamal Heritage with Arm Chair



Nilkamal CHR 4002 without arm chair

Nilkamal STL-10 Round type Stool



Nilkamal STL-15 Squire type Stool



Specification as per Nilkamal design.